

Free Standing - Hardwire - Battery Backup Power System

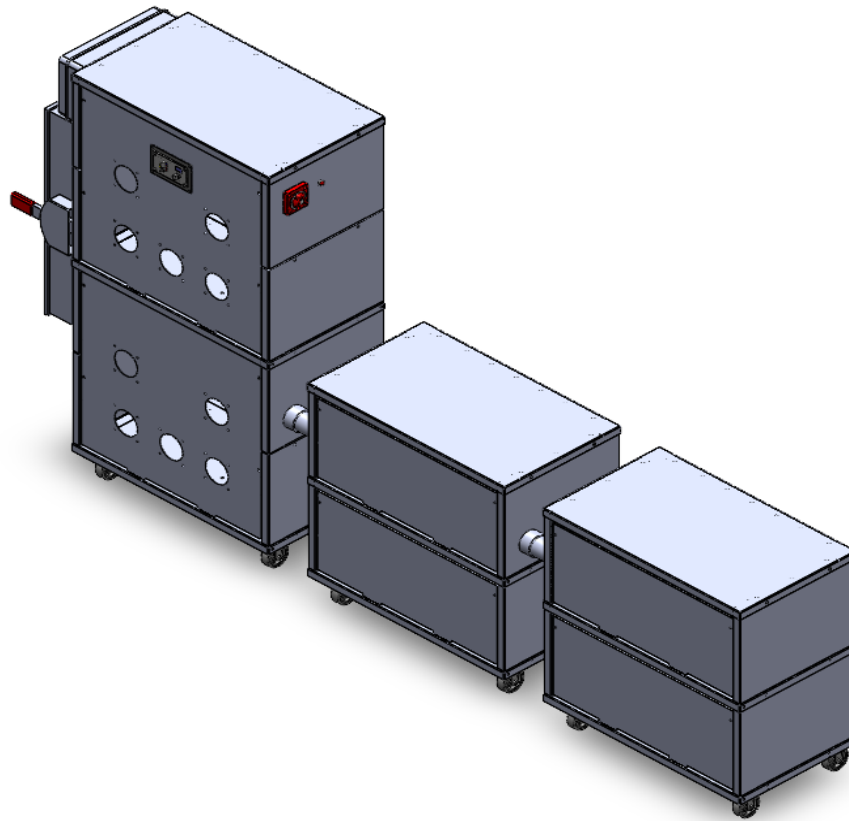

HOW OUR SYSTEMS WORK:

STANDBY MODE

Utility power charges the system and flows through to power the appliance.

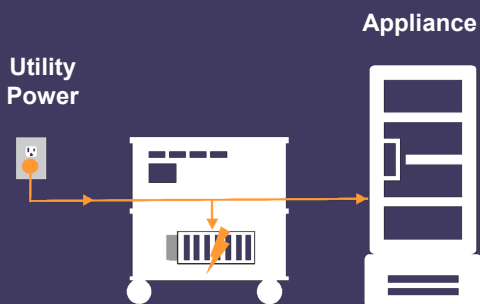

POWER OUTAGE

When utility power is lost the system auto transfers to draw from the battery bank within a second

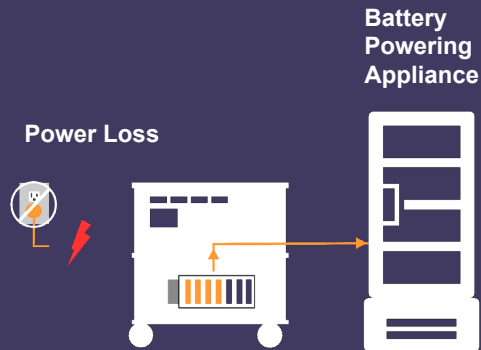

RECHARGE MODE

When utility power is restored the system auto transfers back to utility power.

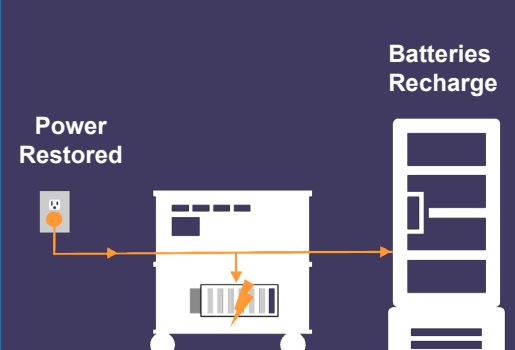

Free Standing - Hardwire - Battery Backup Power System

ELECTRICAL INFORMATION:

Model Number	Wattage	KWH	Phase	Line Power	Load Power	Conductors	Battery Type
MHW200160V	20,000	19.2	Single-Phase	208/240 Volts 100 Amps	208/240 Volts 100 Amps	3 Legs, 1 Netural, 1 Ground	AGM

SYSTEM SIZE

Model Number	Waveform	Width (A)	Depth (B)	Height (C)	Weight (lbs)	Cabinets
MHW200160V	Pure	93.50"	16.50"	54.50"	1,665	3

Note: Unit Onsite Special Certification Inspection - per customer request.

Warranty: 2 Year System Warranty - 4 Year Battery Warranty

UNIT DIMENSIONS

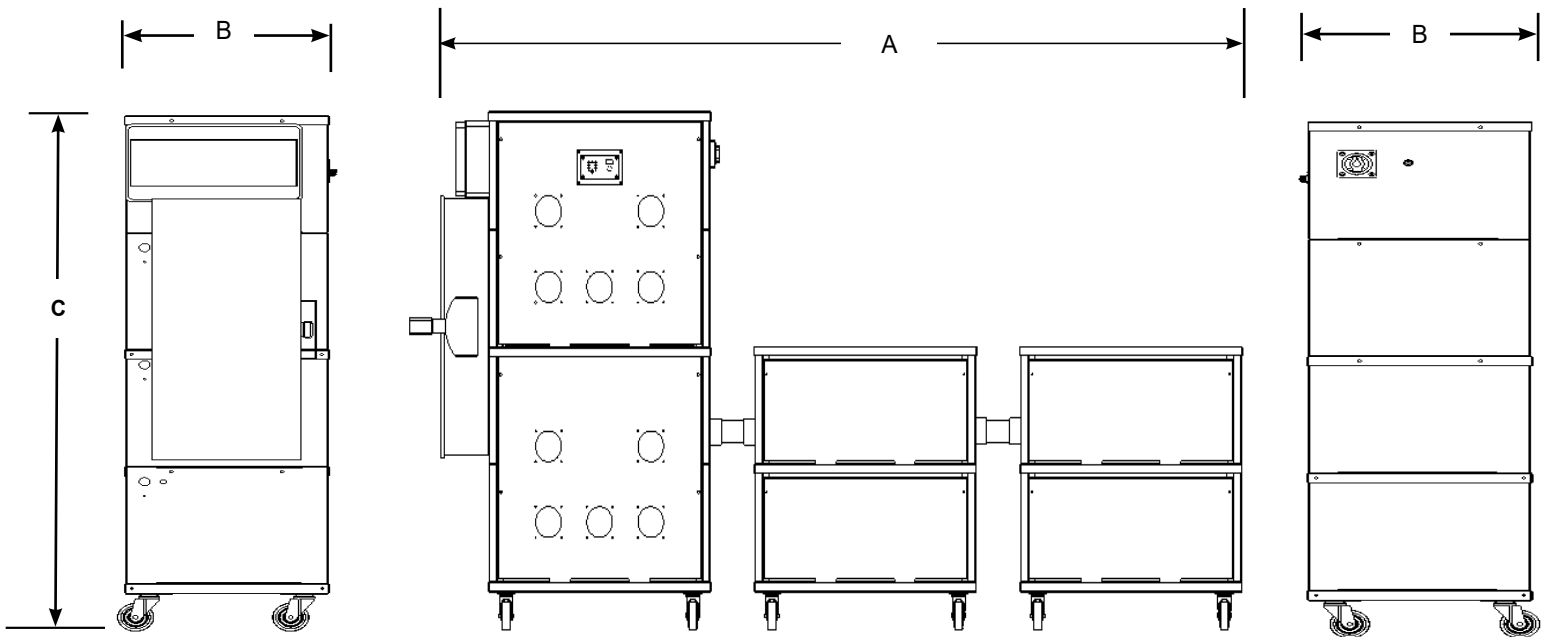

LEFT SIDE

FRONT

RIGHT SIDE