

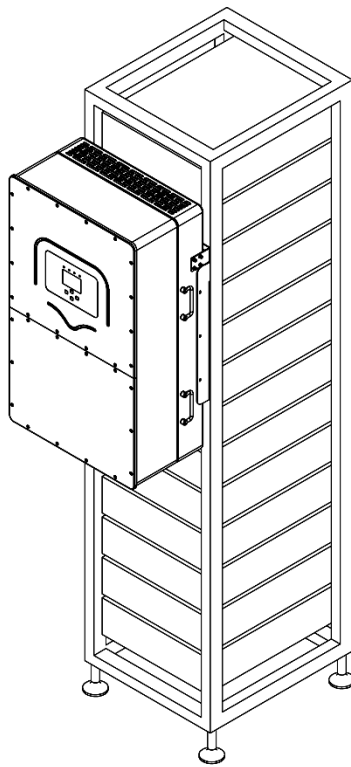

Pillar System User Manual

HV-Series



Model pictured here: P60-12LI600-480

Medicanix, Inc. dba Medi-Products

281 Fields Lane, Suite 2B, Brewster, NY 10509

1.800.765.3237 | www.mediproducts.net

Contents

| | |
|--|----|
| Contents | 1 |
| Safety and Disclaimer | 2 |
| Intended Use and Equipment & Wiring Connections | 2 |
| Statement of Liability for Medical Environments | 2 |
| Installation | 4 |
| Pre-installation Steps: | 4 |
| Installation Steps: | 5 |
| Unit Startup Procedure | 15 |
| Operation | 18 |
| Qualified Technical Support | 18 |
| Testing Procedure | 19 |
| Weekly Testing: | 19 |
| Monthly Testing: | 19 |
| Maintenance Procedure | 22 |
| Unit Shut Down and Battery Replacement Procedure | 23 |
| Warranty Activation Form | 25 |

Safety and Disclaimer

Intended Use and Equipment & Wiring Connections

- This UPS system stores energy. Output battery terminals and possibly output breakers or outlets may be live when the system is turned off or after the input power has been disconnected.
- Please be sure to turn off the electricity in the location where the UPS will be installed prior to working on the unit.
- Please be sure that the power supplied to this unit is the proper phase, voltage and amperage specified.
- The UPS system is required to be powered on a dedicated circuit.
- All hardwired units should be installed by licensed, professional personnel in accordance with local and national codes.
- Although the system is supplied with sealed VRLA batteries they are not leakproof. We recommend that the unit should not be located near explosive medical gas storage, open flame heaters, or electric spark-inducing equipment.

Statement of Liability for Medical Environments

- When used within a surgical environment, do not use in the presence of flammable anesthetic mixtures with air, oxygen, or nitrous oxide.
- This battery backup power system is not intended to support life or run life-supporting equipment but rather to power surgical appliances needed in superficial surgical procedures or medical cold storage appliances. Its use is intended for the supply of emergency power to appliances which may be employed in non-life-threatening medical procedures. It is imperative to understand that at no time should a patient remain unattended. At the time of this manual's writing, the FDA has no classification for a general-purpose medical emergency power supply. This system is not a medical device.
- All life-support type equipment, life-signs monitors, gas monitors etc. are expected to have their own built-in FDA approved appliance-specific energy sources and be maintained correctly. General room lighting and exit signs are also expected to have multiple independent energy sources.

- If life-supporting equipment is to be powered by any sort of electrical source or device, it is Medi-Products' expectation that several alternative independent power supply sources and devices be available.
- Appliances such as refrigerators and freezers, and the contents being stored within them, are the responsibility of the owner/operator to see that they are monitored, maintained and tested. Consequential damages and loss of perishable merchandise are not the liability of Medi-Products/Medicanix.
- It is the sole responsibility of the end user or equipment owner to ensure that the battery backup power system has been tested, maintained, and testing records have been kept and filed.

Installation

Pre-installation Steps:

1) Safety Considerations:

- Read these instructions carefully before attempting to install this product.
- Be sure to leave this manual for end user and save for local inspectors use.
- Observe all governing codes and ordinances.
- Proper installation is the responsibility of the installer.
- Product failure due to improper installation is not covered under the warranty.
- This product should not be altered in any way without manufacturer's consent.
- Be sure all hardwire electrical connections are done by a certified electrical contractor.
- Take special care when working with battery cables, connectors & terminals to make sure they are never short circuited.
- Always wear protective eye, hand and footwear while assembling this system and installing its batteries.

2) Prepare and Check Installation Site:

Identify the area on site where you will be installing the system.

Check all measurements to ensure there will be no obstructions. The necessary height and width requirements will vary with each model, please check your specific unit's spec sheet for this information.

The space directly in front and on either side of the unit will need to be accessible, to remove the unit's access panels for future servicing, or additional connections. You will need at least 3' clearance on any interface of the system. This includes the front of the system, and the front interface of the batteries, the location of which will vary depending on the battery type.

Installation Steps:

Before installing the system, ensure the main power is not energized throughout the entire installation process. Please wait until system is fully installed before applying the main building power to the system. To begin installation, follow the procedure below:

1) Assembling the Frame:

Once delivered, unpack the system, and place the battery frame in the designated installation site. The inverters will come pre-installed to the Battery Frame, so take care not to damage them when moving / installing.

2) Assembling the Batteries:

Once the battery frame is in position and installed, the batteries will need to be installed. Each Frame will hold either 8 Batteries (If Model Number contains "LI400"), or 12 Batteries (If Model Number contains "LI600"). They will also hold the Battery Monitoring System, "BMS", to be placed at the very top of the Frame. This BMS unit will look slightly different from the other batteries (Unit includes a digital screen, switch, lights, etc.). Please see the following diagram (Figure 1) to better identify the Battery BMS unit and the lithium-ion batteries.

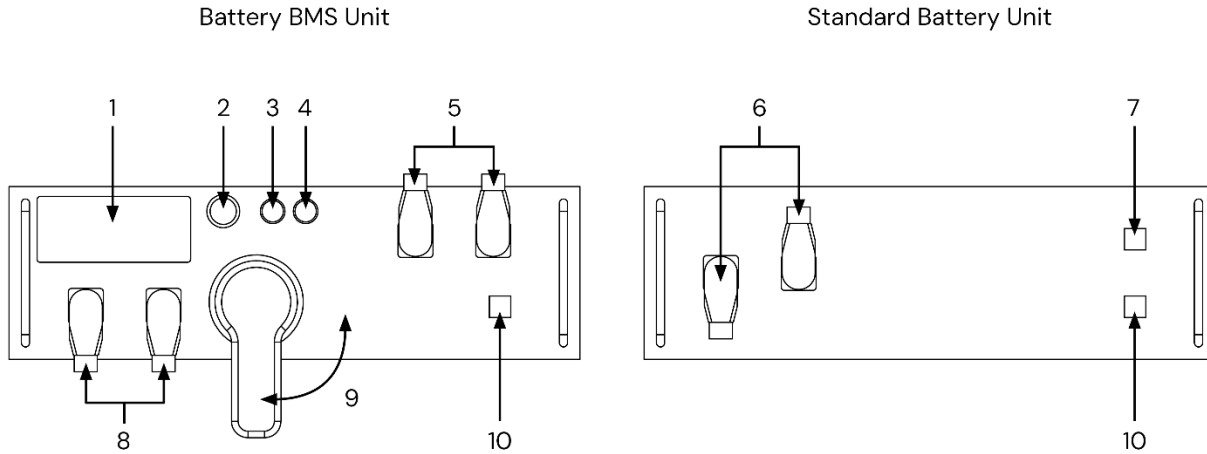

Figure 1

| Number | Component Description | Number | Component Description |
|--------|---------------------------------------|--------|--|
| 1 | Touchscreen Display | 6 | Battery to Battery Connections (+ , -) |
| 2 | BMS Start Button | 7 | Battery Communication Port (IN) |
| 3 | High Voltage Indicator Light (Yellow) | 8 | BMS to Battery Connections (+ , -) |
| 4 | Alarm Indicator Light (Red) | 9 | BMS Disconnect Switch |
| 5 | BMS to Inverter Connections (+ , -) | 10 | Battery Communication Port (OUT) |

Please make sure all batteries are installed properly, into each slot in the Frame and secured to the frame using the included hardware, before moving on.

The system's components have now been assembled, and you are ready to move along to the **AC Input and Output Power Connections** procedure below to properly energize the system.

3) AC Input and Output Power Connections:

Connect the incoming power lines, from the panel designated to feed the UPS system. Each system comes with a Bypass switch pre-installed. Please see the table below to identify the size rating, depending on your model number:

| Beginning of Model Number | Bypass Size (Amps) |
|---------------------------|--------------------|
| P30 | 100 |
| P60 | 80 |
| P120 | 200 |
| P180 | 250 |
| P240 | 300 |

Please see the diagram (Figure 2) on the following page to correctly integrate the Bypass switch into the Medi-Products UPS system:

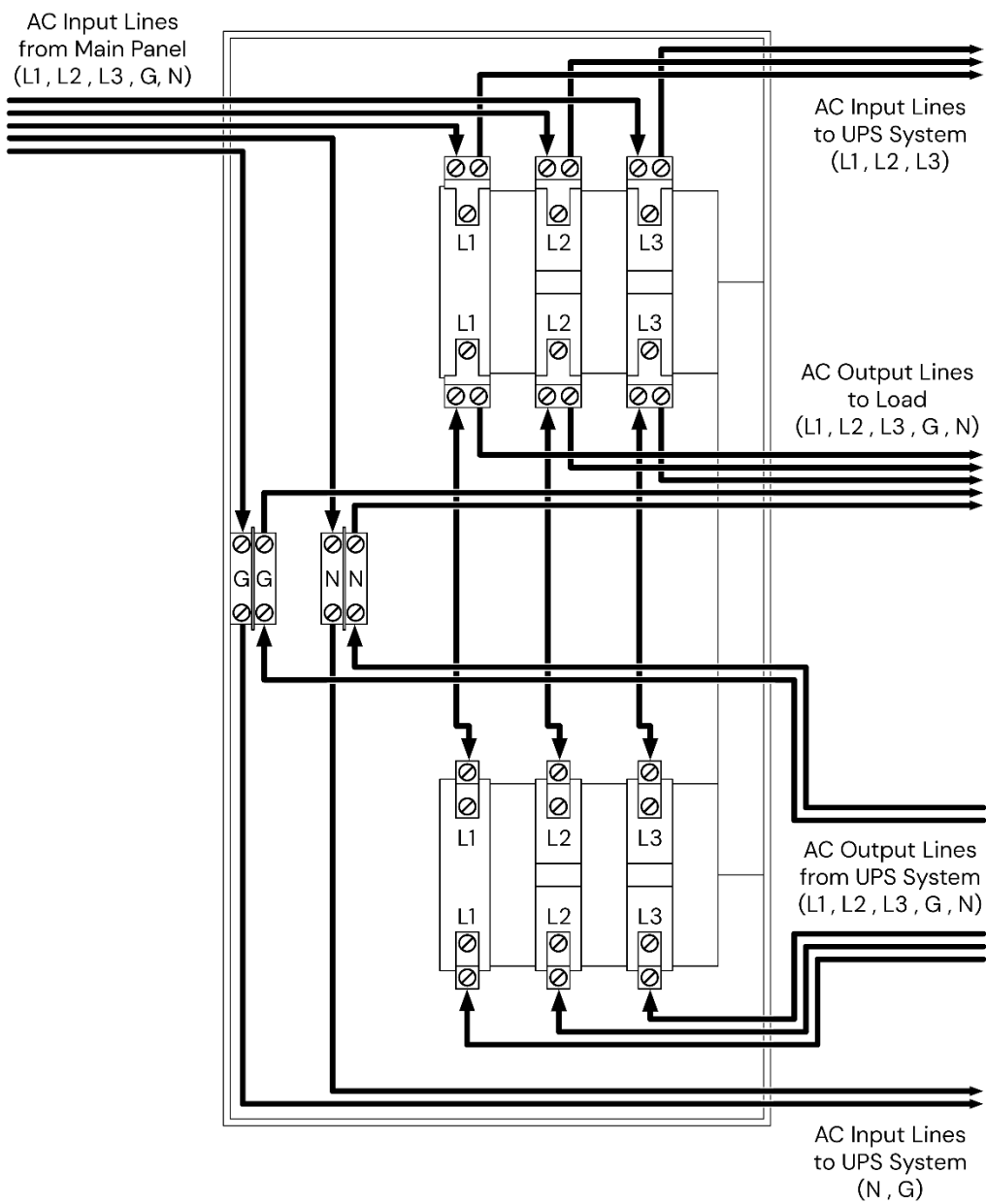

Figure 2

Please see the diagrams on the following pages to correctly install the AC Input and Output cables, based on your specific system.

If your system has only one inverter, follow the diagram below (Figure 3):

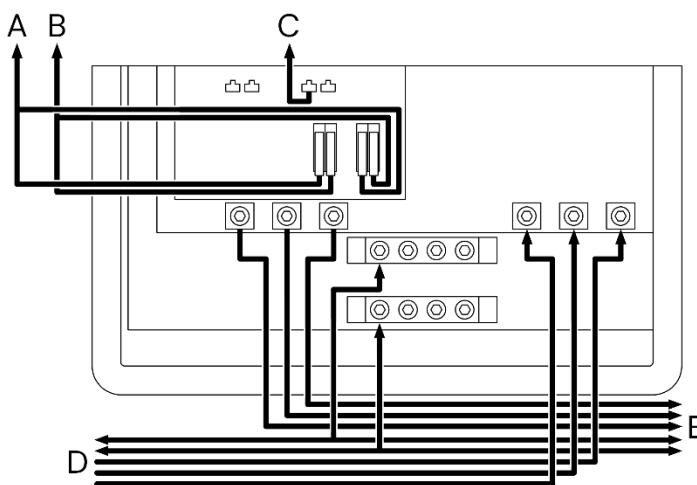

Figure 3

If your system has multiple inverters, follow the diagram below (Figure 4):

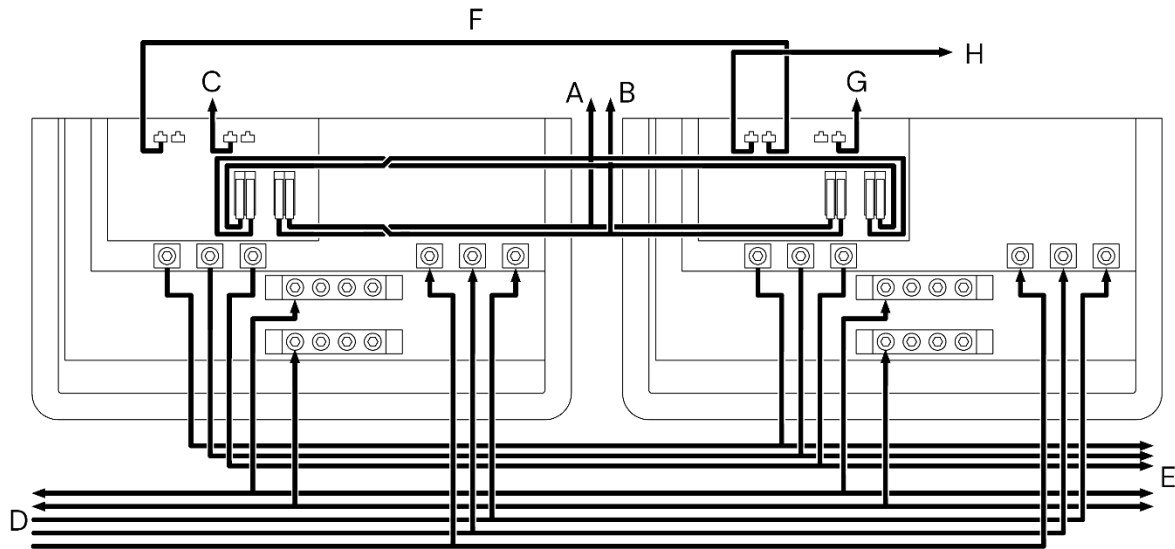

Figure 4

| Indicator | Description |
|-----------|--|
| A | Positive DC Power Cable(s) – To Positive Connector of Battery BMS |
| B | Negative DC Power Cable(s) – To Negative Connector of Battery BMS |
| C | Data Cable – From “PCS” port of Battery BMS #1 to “BMS1” port of Inverter #1 |
| D | AC Input Lines (L1, L2, L3, N, G) from Main Panel via Disconnect Switch |
| E | AC Output Lines (L1, L2, L3, N, G) to Disconnect Switch “Battery” |
| F | Data Cable – From “Parallel 1” port of Inverter #1 to “Parallel 2” port of Inverter #2 |
| G | Data Cable – From “PCS” port of Battery BMS #2 to “BMS2” port of Inverter #2 |
| H | Data Cable – From “Parallel 1” port of Inverter #1 to “Parallel 2” port of next Inverter |

Take note to connect incoming power in correct phase rotation. The UPS system requires a Clockwise rotation and will also require a neutral wire connection.

The **AC Input and Output Power Connections** are now complete, and you are ready to move along to the **DC Power Connections** procedure to properly energize the system.

4) DC Power Connections:

Each Battery in the system will need to be connected in series to the adjacent batteries. Each battery will have a Jumper Cable that will connect the Negative Terminal of one battery to the Positive Terminal of the Battery below it. To help assist this, the Jumper Cable will have a black connector on one end, for the Negative Terminal, and an orange connector on the other end, for the Positive Terminal.

The final battery in the Frame will have a much longer Black Cable that will connect the Negative Terminal on that battery to the Negative Terminal of the Battery BMS Unit. Additionally, the Battery directly below the Battery BMS Unit will connect from its Positive Terminal to the BMS Unit's Positive Terminal, completing the series of Battery Connections. Please see Figure 5 on the next page to better understand the connections.

5) Additional Connections Required:

Each battery in the battery frame also needs to communicate with each other. This will be done through short RJ45 jumper cables, that reach from one battery to the one below it.

Please see the diagram on the following page (Figure 5) to ensure the battery connections are made properly.

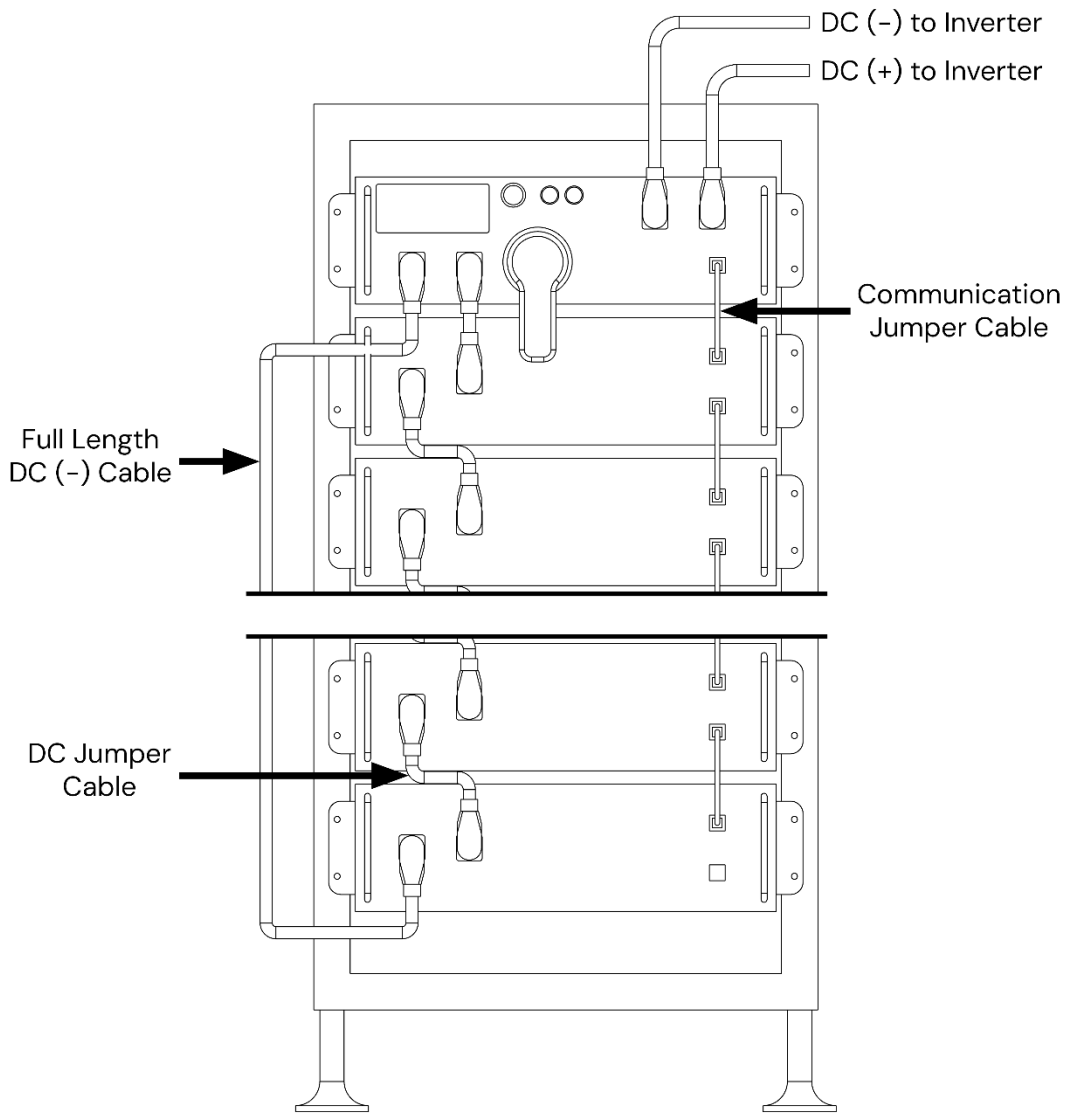

Figure 5

Additionally, the system will require communication cables to be connected between the inverters and the batteries, through the battery BMS unit(s). Depending on the configuration of your system, please refer to the following diagrams to complete the installation:

If your system includes only one inverter and one battery stack (please see specification sheet to determine this), please follow the diagram (Figure 6) below.

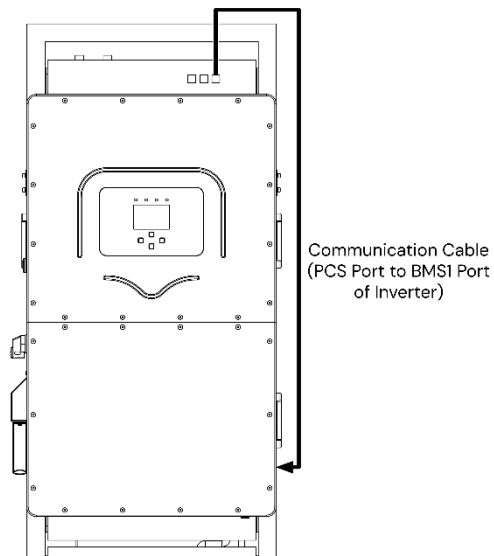

Figure 6

If your system includes one inverter and multiple battery stacks (please see specification sheet to determine this), please follow the diagram (Figure 7) below.

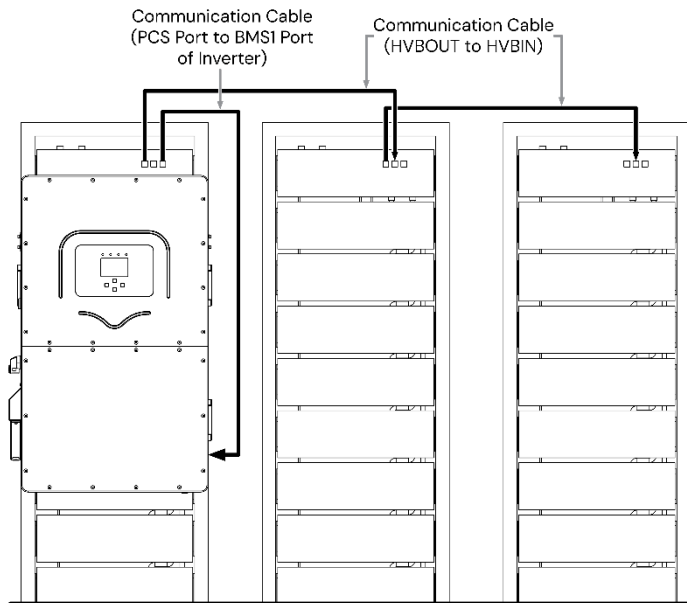

Figure 7

If your system includes multiple inverters and multiple battery stacks (please see specification sheet to determine this), please follow the diagram (Figure 8) below.

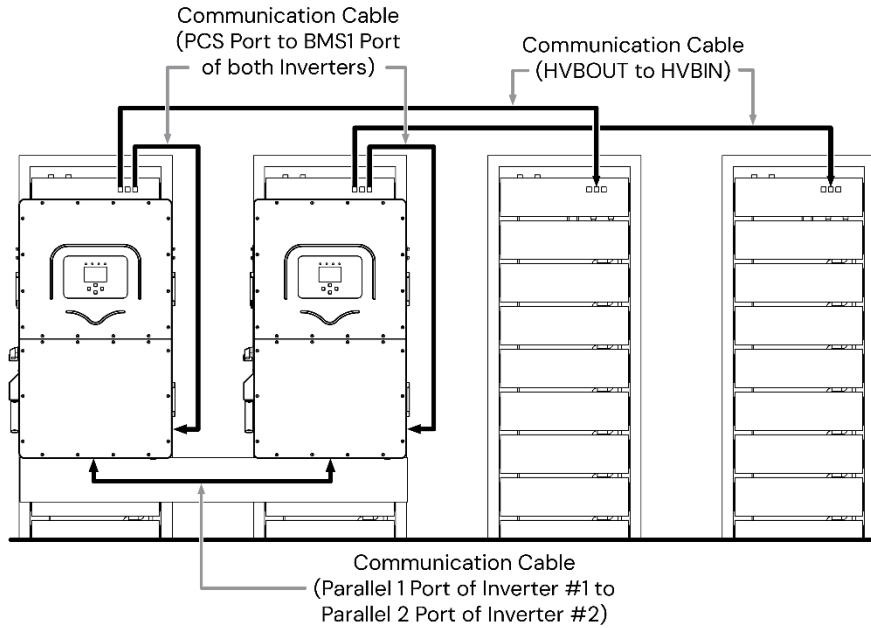

Figure 8

All wiring (AC, DC, and additional connections) is now complete, and you are ready to move along to the **Unit Startup Procedure** to properly energize the system.

Unit Startup Procedure

Upon completing each step of the Installation process, follow these steps to start using your system. If at any point a step is unsuccessful, or you have any questions, please call our Technical Support line for assistance, at 800-765-3237.

Before you begin, ensure that the system is unpowered by the main supply. Additionally, ensure that the Battery BMS Disconnect Switch is in the “off” position, with the handle being vertical. Also make sure that the Battery BMS Start Button is in the “off” position, with the button being flush, and not pressed in. On the inverter(s), make sure that PV Switch 1 and PV Switch 2 are in the “off” position, with the handles being vertical. Also make sure the Inverter Power Button is in the “off” position, with the button being flush, and not pressed in.

Before following the guide below, ensure all voltages are correct, both DC and AC. Each “Stack” of batteries will contain either 8x batteries (“XXLI400” in model number), or 12x batteries (“XXLI600” in model number). The “LI400” models have a nominal voltage of 410Vdc, with an operating range of 392Vdc – 448Vdc. The “LI600” models have a nominal voltage of 614.4Vdc, with an operating range of 588Vdc – 672Vdc. To ensure the stack of batteries is within the appropriate operating range, use a digital multimeter to measure the stack’s voltage. Do so by removing the first batteries’ Positive cable that connects to the Battery BMS unit, and the full length Negative cable that connects the last battery to the Battery BMS unit. Apply the two probes of the digital multimeter to the now open connector terminals of the first and last battery to determine the total stack’s DC Voltage. Repeat this process for all battery stacks in the system. If the DC Voltage you measure does not fall within the operating voltage range of the system, please call our Technical Support line for assistance, at 800-765-3237.

Ensure that the AC Voltage being fed to the system also conforms to the required electrical information, as per your specific model. If the model number ends with “-208”, the system requires a 208Y/120V, 4 Wire input connection. If the model number ends with “-480”, the system will require a 480Y/277V, 4 Wire input connection. Ensure that the Line-to-Line, and Line-to-Neutral incoming voltage is consistent with this information, otherwise the system will not function properly.

The system is now prepared for the **Unit Startup Procedure**.

To perform the **Unit Startup Procedure**, follow the guide below:

- 1) After verifying all Vdc and Vac numbers are accurate and consistent with the requirements, begin by turning the BMS Disconnect Switch to the “on” position (horizontal). This switch will click into place when switched properly.

- 2) Next, Press the BMS Start button. You will see the boot-up screen appear on the touchscreen of the BMS unit. After a few seconds, the “High Voltage Indicator Light” will illuminate. After waiting a few more seconds, tapping the screen will bring you to the BMS Home Screen, which will display current information for the batteries. From this screen, you can monitor the Battery Voltage, Battery State of Charge, and the Charge/Discharge Current.

- 3) Once the batteries have been turned on, you can move on to the Inverter(s). Locate the two “PV Switches” on the left side of each Inverter. Turn “PV Switch 1” on first, and then “PV Switch 2”, on all inverters in the system.

- 4) Next, If only one Inverter is in the system, press the Inverter Power Button (Blue button on left side of inverter), pressing “in” to the “on” position. If there are multiple Inverters, you must turn on the Slave units first before the Master inverter can be turned on (Master Inverter will be the “furthest left” Inverter when looking at system). The system will likely show a fault message when doing so, however this will clear momentarily. Once the Inverter(s) have been turned on, wait for the “Normal” LED light to illuminate, this may take a few minutes.

- 4) At this time, the system will be outputting AC power by inverting DC power from the batteries. To check if the output is correct, use your digital multimeter to measure the Vac on the output of the system. Ensure the output power is consistent with the input power (Line-to-Line, and Line-to-Neutral), despite the input not yet being connected. This ensures the equipment downstream will be powered correctly whether on the main power (pass-through mode), or battery backup mode, when main power is lost. Before applying the main power, ensure any equipment downstream is being powered correctly.

5) Next, turn “on” any Grid disconnect switch, to have main AC power present on the input terminals of the inverter. The “AC” LED light will illuminate when AC voltage is present on Input terminals of the inverter.

6) With AC power now present on the Inverter(s) input terminals, the system will automatically begin passing through the main power and charge the batteries at the same time. At this time, verify again that any equipment downstream is still being powered correctly.

The Medi-Products UPS system is now fully operational.

Warning – Each System comes pre-programmed to work in that installation. After initializing your system, parameters within the various menus shall not be changed. This can result in damage to the system or equipment and can void the system’s warranty.

Operation

During normal operation, when the main power is available to the system, the “Normal”, “DC”, and “AC” lights will be illuminated. Please see below if this is not the case after Unit Startup:

| | “DC” LED Indicator | “AC” LED Indicator | “Normal” LED Indicator | “Alarm” LED Indicator |
|---------|--|--|---|---|
| LED On | (Green) = DC input is connected and provides proper voltage | (Green) = AC input (Grid) is connected and provides proper voltage. | (Green) = System is fully energized (AC and DC present) and is operating. | (Red) = System is in an Alarm state. To check the Fault code, press the “Settings” icon in the top right corner of the home screen, and then the “System Alarms” tab. |
| LED Off | Minimum Vdc is not being met, Battery input has wrong polarity, etc. | Main power to system is not present, grid voltage is out of acceptable range or is disconnected from system. | System is not fully energized (AC and/or DC not present), System in a fault state, or system is in pass-through mode. | No alarms / errors present. |

Please call the Medi-Products Technical Support number if any assistance is needed.

Qualified Technical Support

Adjustments can be made to the inverter module, if necessary. Please consult with technical service prior to making any adjustments, as unit should arrive with adjustments preset.

A large amount of energy is stored in the batteries which can cause injury to unqualified persons attempting to effect repairs. Also, no one untrained regarding electrical energy should attempt any service task or remove any of the front covers as live circuits will be exposed in all cases.

Eye protection should be worn by any person connecting or disconnecting batteries and battery cables.

Hand & Eye Protection is recommended for any person handling batteries.

Medi-Products | Pillar System User Manual

Medicanix Inc. 281 Fields Lane, Suite 2B, Brewster, NY 10509

1.800.765.3237 | www.mediproducts.net

Testing Procedure

Standards of testing the power system must be implemented and carried out along with your regular testing policies.

Medi-Products sets out the following guidelines and instructions that must be understood and implemented for the use and dependence on our battery backup generators.

Weekly, and Monthly load tests must be performed, recorded and documented. The following criteria must be followed to complete each test:

Weekly Testing:

The recommended weekly test is a quick and simple test which assures the functionality of the transfer switch, auto-invert and charge modes.

This test is performed by disconnecting the power that feeds the battery backup unit or if your system is a plug and play standalone system, unplug its power cord. Upon disconnecting the feed power, your system should switch over to invert mode and draw its power from the batteries. At this point, you should be sure your equipment is still on and running.

Note: If you need to find out your “runtime” contact tech support with your power system’s model and serial number and the make and model of the refrigerator or freezer you are supporting. If you are supporting operating room equipment the standard runtime is 2 hours.

After you have ensured that your system has switched over and is inverting, you will need to restore the feed power (or plug the system back in). This test should not last more than 2 to 3 minutes.

Monthly Testing:

The monthly test is a load test that needs to be conducted no sooner than 20 days and no longer than 40 days from the prior (monthly) load test. This test is to ensure the generator can last 25% of its intended runtime. Your runtime is a predetermined amount of time that your refrigerator will run on the battery backup. This would have been calculated at the time you purchased the unit.

Example: 12 hour run time = Monthly test 3 hours

For the week you are performing the monthly test, it is not necessary to also perform the weekly test.

Another important issue to take note of is that it is possible to over test your power system. Medi-Products battery backup Pillar systems use Lithium-ion batteries, which if discharged too frequently or discharged too deeply, it can cause damage to the batteries, shortening their life expectancy and weakening the health of the battery.

You may want to set a timer to remind you to restore the input power to the system and not over discharge the batteries. Reconnect the input power and recharge the battery bank. This may take several hours.

Record Keeping:

Recording these tests is important for the protection of your vaccines and costly inventory. You can use our example test logs on the following page, and can download more from our website if needed.

Maintenance Procedure

The Medi-Products system contains virtually no moving or lubricated components and therefore requires almost no user maintenance aside from testing, recordkeeping and periodically replacing the batteries (every 10 years).

The user should be aware that by their nature, battery life is negatively affected by some usage patterns. Of course, batteries are intended to be used, but minimizing deep discharges, and frequent charge / discharge cycles will extend overall life. Their life expectancy will generally be about 10 years. Please refer to the section on Battery Testing for more on this subject.

The system has a battery voltage alarm which will sound when the battery voltage drops below a set value. Battery voltage indicators should be checked if the alarm sounds. Often a low battery alarm will result from a tripped input supply breaker in the main building electric panel. If this is not the cause, please contact Medi-Products promptly.

Unit Shut Down and Battery Replacement Procedure

If the system needs to be turned off to move the system, replace the battery modules, or perform any maintenance, please follow these steps:

- 1) Begin by ensuring all appliances / loads are powered via different means while the system is being disconnected, to avoid any damage or loss of power.
- 2) Cut the main input power to the system, by flipping the breaker that feeds the system from the main panel.
- 2) Next, turn the Battery BMS Disconnect Switch to the "off" position. Then, press the "BMS Start button" to turn it "off". Wait about 2 minutes to completely de-energize, ensure the "HV" indicator light is no longer illuminated before moving on.
- 3) Turn the two "PV Switches" on each (if multiple) inverter in the system to the "off" position.
- 4) Press the Inverter Power Button on each inverter to completely turn the system off.

Please wait another 1-2 minutes to let the system completely de-energize before disconnecting any cables, if doing so.

5) If replacing the system's batteries, begin by disconnecting all Battery and Communication jumper cables between the batteries in each Battery frame. To assist in replacing the new batteries, it would be advised to take multiple pictures showing the configuration of these cables before disconnecting.

6) Once all battery cables have been disconnected, each battery can be removed from the Frame. Do this by unscrewing each battery, and physically removing it.

If the system is to be physically moved, now would be the time to do so, before replacing any batteries. Before moving the system, the AC wiring into and out of the system must be removed. It may also be beneficial to remove the inverter from the Battery frame, as moving the frame with the inverter attached may prove challenging. Be sure to take all proper precautions when moving the system, and call the Medi-Products Tech Support line for guidance before doing so.

7) Now, replace each old battery with a new one, securing them to the frame as you go. If the system was physically moved, ensure everything that was removed has been reinstalled correctly, follow all guides in this manual to do so.

8) Reconnect the Battery and Communication jumper cables, referring to the pictures taken earlier if necessary.

9) Now that the battery modules have been replaced and the system has been re-installed, please refer to the **Unit Startup Procedure** section to verify that the system is operational again.

Warranty Activation Form

Medi-Products warrants that your Emergency Power System is assembled using high quality components and workmanship and is free of defects in material and workmanship. This warranty shall remain in effect for two (2) years from the date of the original consumer purchase of the inverter. Warranty on the batteries is pro-rated over 48 months.

THIS WARRANTY DOES NOT COVER:

- 1) Replacement parts or labor furnished by anyone other than Medi-Products approved service agent. (All approved agents should be licensed electricians or bio-medical technicians or as specifically approved).
- 2) Defects or damage caused by labor furnished by someone other than Medi-Products or an approved service agent.
- 3) Any malfunction or failure of this product while it is in the possession of the owner during the warranty period, if the malfunction or failure is not caused by a defect in material and workmanship of Medi-Products, or if the malfunction or failure is caused by unreasonable use, including the failure to verify the equipment's utility and usefulness prior to emergency conditions.
- 4) Normal battery depletion.

ALSO:

- 1) This warranty is non-transferable to other owners of the product during the warranty period without the express written consent of Medi-Products.
- 2) Medi-Products reserves the right to repair, replace, or allow credit for any material returned under this warranty. Any damage caused by the customer will be charged or deducted from this allowance.
- 3) All warranty work will be performed at Medi-Products factory or using a valid Warranty Authorization Number (WAN) prior to repair. Products shall be delivered to Medi-Products factory freight prepaid and fully insured.

The inverter manufacturer's owner's manual is provided. The owner should become conversant with it and with this owner's manual. Before operating your system be sure to read these safety instructions.

TO INITIATE YOUR WARRANTY PLEASE COMPLETE THIS FORM AND RETURN WITHIN 30 DAYS

It is recommended that you keep a copy of this activation form for your own records.

Model Number: _____

Serial Number: _____

Date of installation: _____

Facility Name: _____

Contact Name: _____

Phone Number: _____

Fax Number: _____

Email Address: _____

Address where System is installed:

Scan and email this form to sales@mediproducts.com, or you can mail it to
Medicanix Inc. 281 Fields Lane, Suite 2B, Brewster, NY 10509.



Medicanix, Inc. dba Medi-Products

281 Fields Lane, Suite 2B, Brewster, NY 10509

1.800.765.3237 | www.mediproducts.net