

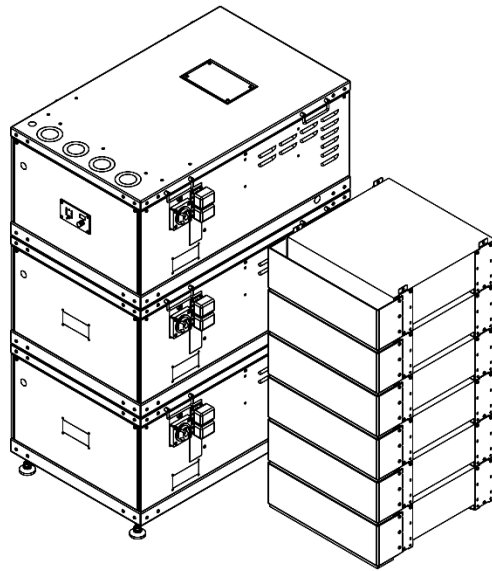

Pillar System User Manual

LV-Series



Pictured here: P45-6LI48-480

Medicanix, Inc. dba Medi-Products

281 Fields Lane, Suite 2B, Brewster, NY 10509

1.800.765.3237 | www.mediproducts.net

Contents

| | |
|--|----|
| Contents | 1 |
| Safety and Disclaimer | 2 |
| Intended Use and Equipment & Wiring Connections | 2 |
| Statement of Liability for Medical Environments | 2 |
| Installation | 3 |
| Pre-installation Steps: | 3 |
| Installation Steps: | 4 |
| Unit Startup Procedure..... | 17 |
| Operation | 19 |
| Output Indicators | 19 |
| Charging Indicators | 22 |
| Special Indicators..... | 23 |
| Troubleshooting..... | 24 |
| Qualified Technical Support | 26 |
| Testing Procedure | 27 |
| Weekly Testing: | 27 |
| Monthly Testing: | 28 |
| Maintenance Procedure | 30 |
| Unit Shut Down and Battery Replacement Procedure | 31 |
| Warranty Activation Form | 33 |

Safety and Disclaimer

Intended Use and Equipment & Wiring Connections

- This UPS system stores energy. Output battery terminals and possibly output breakers or outlets may be live when the system is turned off or after the input power has been disconnected.
- Please be sure to turn off the electricity in the location where the UPS will be installed prior to working on the unit.
- Please be sure that the power supplied to this unit is the proper phase, voltage and amperage specified.
- The UPS system is required to be powered on a dedicated circuit.
- All hardwired units should be installed by licensed, professional personnel in accordance with local and national codes.
- Although the system may be supplied with sealed VRLA batteries, they are not leakproof. We recommend that the unit should not be located near explosive medical gas storage, open flame heaters, or electric spark-inducing equipment.

Statement of Liability for Medical Environments

- When used within a surgical environment, do not use in the presence of flammable anesthetic mixtures with air, oxygen, or nitrous oxide.
- This battery backup power system is not intended to support life or run life-supporting equipment but rather to power surgical appliances needed in superficial surgical procedures or medical cold storage appliances. Its use is intended for the supply of emergency power to appliances which may be employed in non-life-threatening medical procedures. It is imperative to understand that at no time should a patient remain unattended. At the time of this manual's writing, the FDA has no classification for a general-purpose medical emergency power supply. This system is not a medical device.
- All life-support type equipment, life-signs monitors, gas monitors etc. are expected to have their own built-in FDA approved appliance-specific energy sources and be maintained correctly. General room lighting and exit signs are also expected to have multiple independent energy sources.
- If life-supporting equipment is to be powered by any sort of electrical source or device, it is Medi-Products' expectation that several alternative independent power supply sources and devices be available.
- Appliances such as refrigerators and freezers, and the contents being stored within them, are the responsibility of the owner/operator to see that they are monitored, maintained and tested. Consequential damages and loss of perishable merchandise are not the liability of Medi-Products/Medicanix.
- It is the sole responsibility of the end user or equipment owner to ensure that the battery backup power system has been tested, maintained, and testing records have been kept and filed.

Installation

Pre-installation Steps:

1) Safety Considerations:

- Read these instructions carefully before attempting to install this product.
- Be sure to leave this manual for end user and save for local inspectors use.
- Observe all governing codes and ordinances.
- Proper installation is the responsibility of the installer.
- Product failure due to improper installation is not covered under the warranty.
- This product should not be altered in any way without manufacturer's consent.
- Be sure all hardwire electrical connections are done by a certified electrical contractor.
- Take special care when working with battery cables, connectors & terminals to make sure they are never short circuited.
- Always wear protective eye, hand and footwear while assembling this system and installing its batteries.

2) Prepare and Check Installation Site:

Identify the area on site where you will be installing the system.

Check all measurements to ensure there will be no obstructions. The necessary height and width requirements will vary with each model, please check your specific unit's spec sheet for this information.

The space directly in front and on either side of the unit will need to be accessible, to remove the unit's access panels for future servicing, or additional connections. You will need at least 3' clearance on any interface of the system. This includes the front of the system, and the front interface of the batteries, the location of which will vary depending on the battery type.

Installation Steps:

Before installing the system, ensure the main power is not energized throughout the entire installation process. Please wait until system is fully installed before applying the main building power to the system. To begin installation, follow the procedure below:

1) Assembling Inverter Boxes:

To begin installing the system, identify the number of “Inverter Boxes” your system has, see the table below to determine this based on your UPS system’s Model Number:

| Beginning of Model Number | Number of Inverter Boxes |
|---------------------------|--------------------------|
| P18 | 3 |
| P20 | 2 |
| P30 | 3 |
| P40 | 4 |
| P45 | 3 |
| P60 | 6 |

Each Inverter Box will be numbered, and will be installed so that the top Inverter Box is Inverter Box #1, and the bottom is the last number in the sequence. Once all have been identified, find the “last” Inverter Box in the system. For example, if your system comes with 4 Inverter Boxes, the last Inverter Box will be labelled “#4”. This Inverter Box will be the only box with Feet installed on the underside. Place this box first, in the area where the system will be installed.

Next, using the included handles or a lifting device, place the next box on top of the first box. Following the previous example, this Inverter Box will be labelled “#3”. Continue this sequence until you have placed all Inverter Boxes, ensuring the very last Inverter Box installed is labelled “#1”.

To continue with the installation process, the “Front Cover” of each Inverter Box will need to be removed to allow access to the inside where the AC Wiring must be connected. To do this, identify the Front Cover (Figure 1 below), and remove the two screws holding the cover in place. After removing the screws, pull towards you and lift slightly to release the locating tabs on the bottom of the cover, and set aside for later. Be sure to re-install the covers after system has been fully installed.

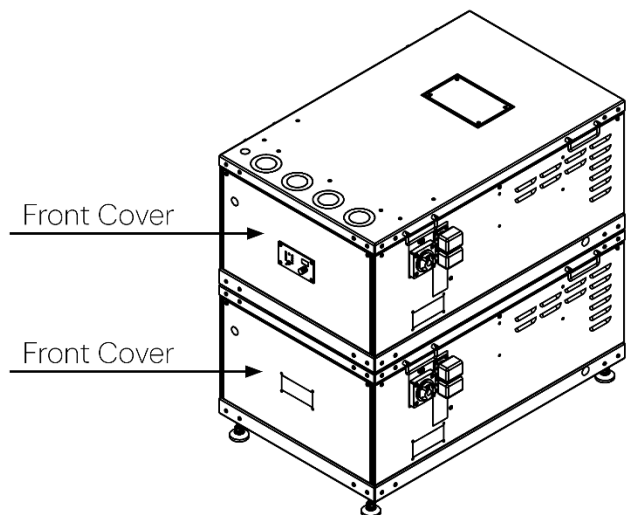

Figure 1

2) Assembling the Batteries:

Depending on your system’s Model Number, please follow the appropriate instructions below, to assemble the batteries properly:

A) Lead-Acid Battery System, Models with “XXLA48”

These systems utilize lead-acid batteries, arranged in a 48v configuration. The batteries are located within stainless steel carts and will arrive pre-wired. Align the Battery Carts to be within 6 inches of the side of the Inverter Box stack. Please refer to the spec sheet for your

specific model to verify where to move the Battery Carts and ensure the front cover of each cart is easily accessible for future battery replacements.

B) Lithium-Ion Battery System, Models with “XXLI48”

These systems utilize lithium-ion batteries, which will need to be arranged in a specific pattern to ensure proper communication with the Inverter Boxes. Much like the Inverter Boxes, each lithium-ion battery will have a specific designation, clearly labelled on the front face of the battery. The number of lithium-ion batteries in your system will determine how to stack each battery. Please look at the spec sheet for your specific model to see how the batteries will need to be assembled.

Before placing the batteries, please note that the lithium-ion batteries must be placed in a specific sequence, to ensure proper communication. The Batteries will come pre-programmed for their specific sequence, so improper placement will result in incompatible communication, and will not allow system to operate as intended.

Please carefully review the example image below (Figure 2) to understand the sequence of placing batteries:

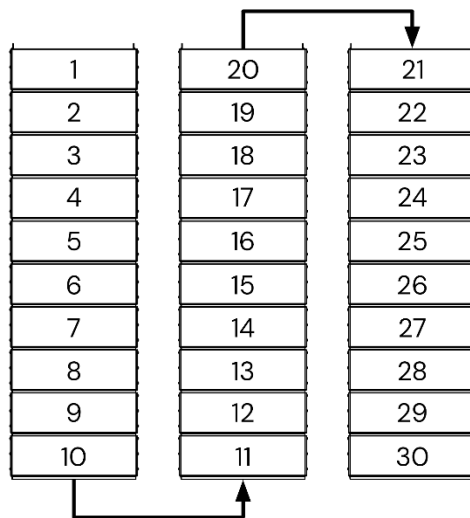

Figure 2

Note that from one stack of lithium-ion batteries to the next (Left to Right), the sequence will reverse, as the sequence needs to stay consistent from one battery to the next. While the example image has three stacks of 10 individual batteries, this layout will be true for any number of batteries in a single stack.

Once the proper sequence has been identified (Using the example image above along with the spec sheet of your specific model), begin by placing the first battery. If multiple stacks of batteries are included, start by placing the first battery in each stack. Using the tabs on the top of each corner bracket, place the next battery such that the tab locates into the corresponding slot on the bottom of the corner bracket. Use the included ¼"-20 screws to secure the battery to the one below it. Repeat this process until all lithium-ion batteries have been assembled in the proper configuration.

The system's components have now been assembled, and you are ready to move along to the **AC Input and Output Power Connections** procedure below to properly energize the system.

3) AC Input and Output Power Connections:

Connect the incoming power lines from the panel designated to feed the UPS system to the Terminal Blocks found within the top Inverter Box (Box #1). If a Bypass switch is to be installed, please see the table below to determine the size needed, depending on your model number:

| Beginning of Model Number | Suggested Bypass Size (Amps) |
|---------------------------|------------------------------|
| P18 | 60 |
| P20* | 100 |
| P30 | 100 |
| P40* | 250 |
| P45 | 60 |
| P60 | 200 |

Note, the systems in the table with (*) will require a Two Pole switch, while the rest are Three Pole switches. Keep in mind these values can also be used for overcurrent protection to the load.

Please see the diagram below (Figure 3) to correctly integrate the Bypass switch into the Medi-Products UPS system:

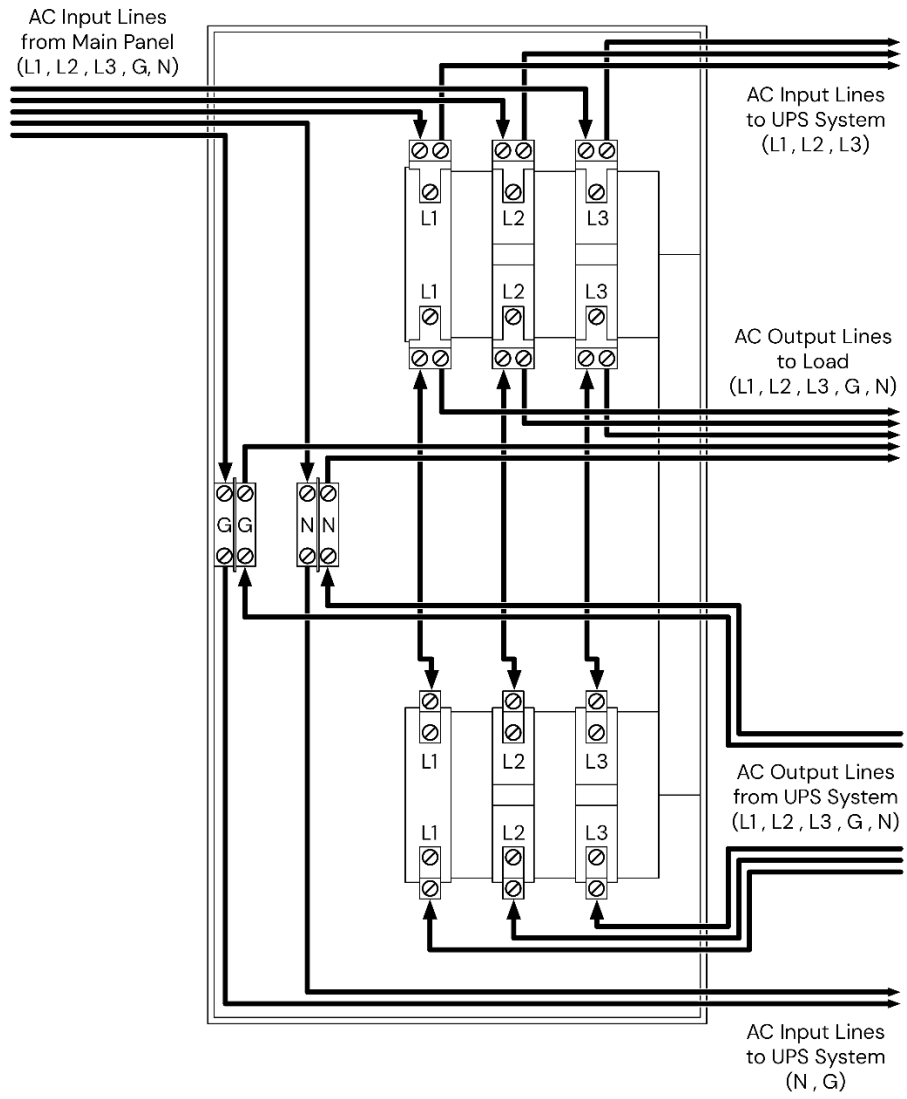

Figure 3

Take note to connect incoming power in correct phase rotation. The UPS system requires a Clockwise rotation and will also require a neutral wire connection. Please see the diagrams below to determine how the power lines will be landed, depending on the UPS system's Phase requirements.

If the Model number of your system begins with P30, P45, or P60, please follow the diagram for Three Phase Systems, below:

For Three Phase systems:

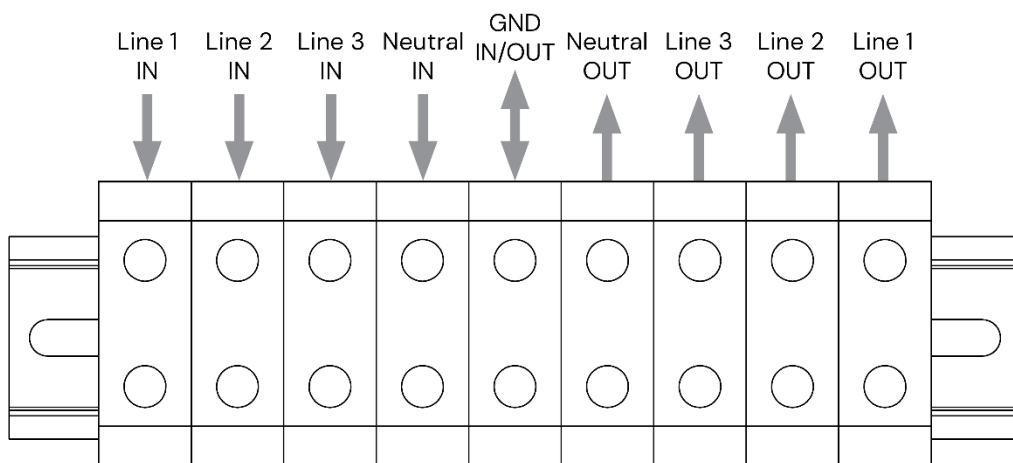

Figure 4

If the Model number of your system begins with P20, or P40, please follow the diagram for Split Phase Systems, below:

For Split Phase Systems:

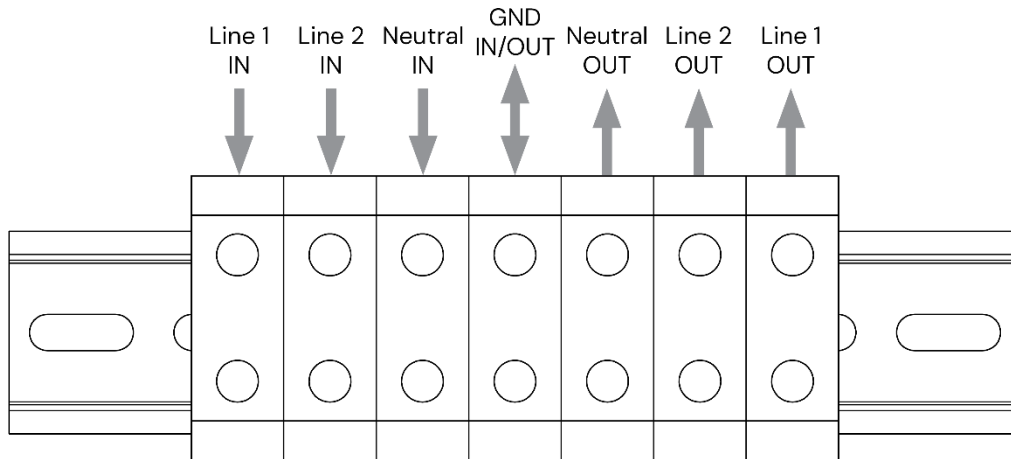
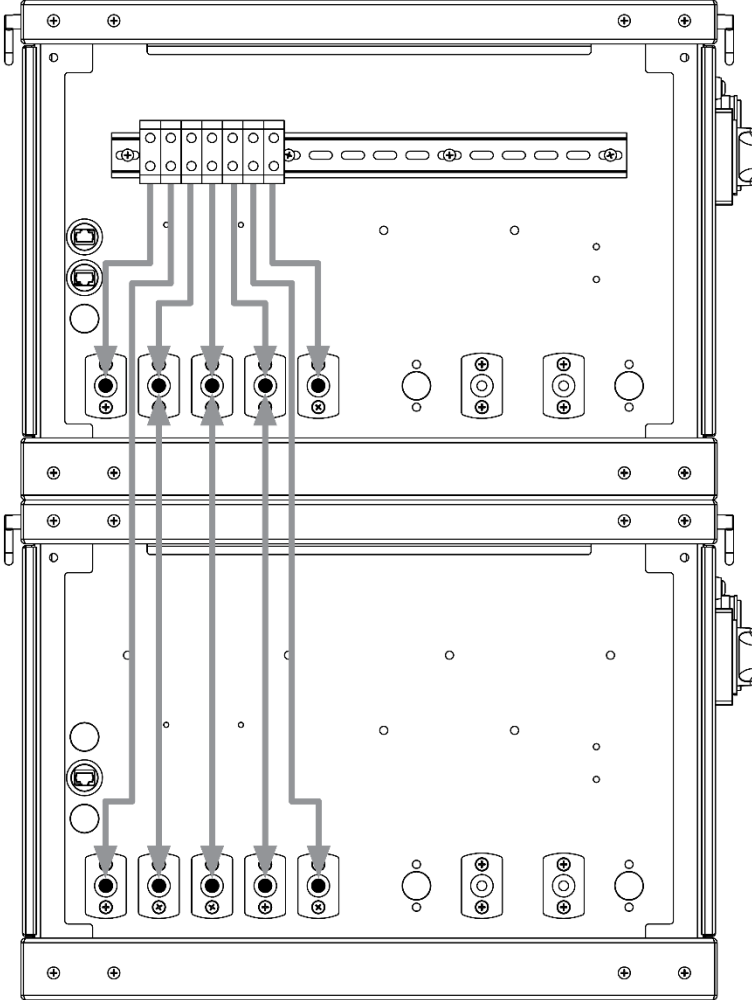

Figure 5

Once the power lines from the facilities' main power have been installed, the pre-sized power cables can then be connected to the existing posts on the interior of the UPS system.

Follow the corresponding wiring configurations in the following pages depending on the Model Number of your system, to connect the AC wiring cables within the system:

A) AC Wiring Diagram for "P20" Models:



B) AC Wiring Diagram for "P30 / P45" Models:

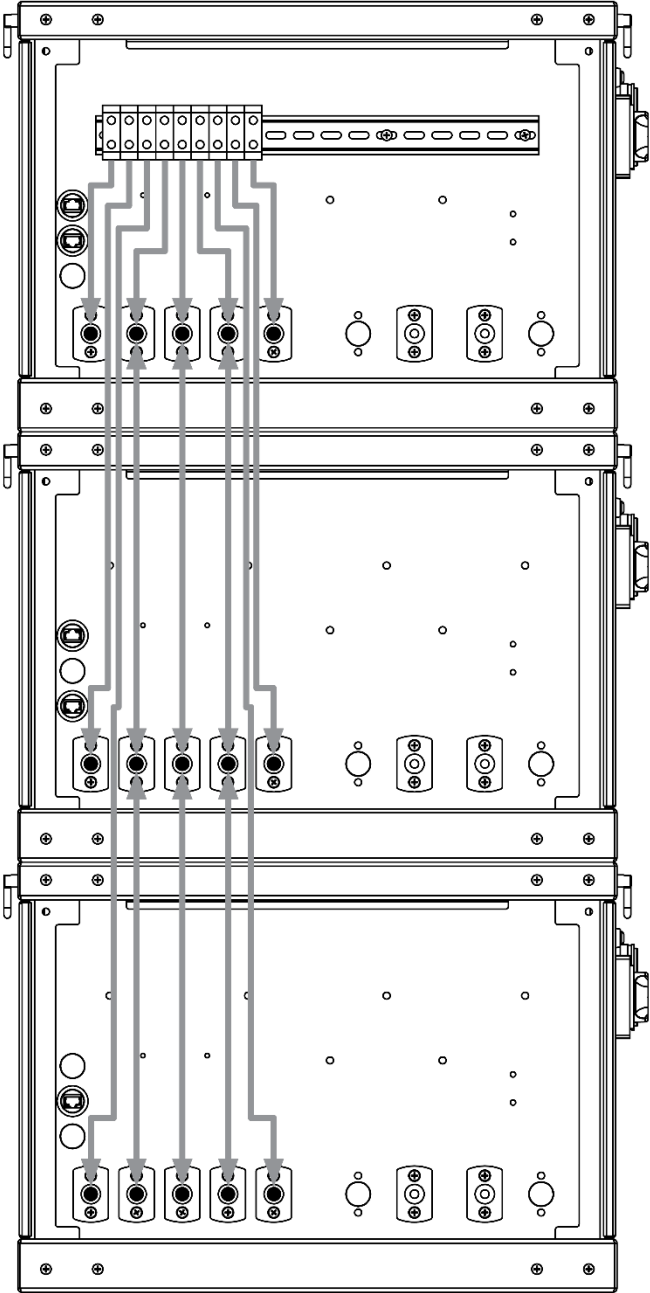

C) AC Wiring Diagram for "P40" Models:

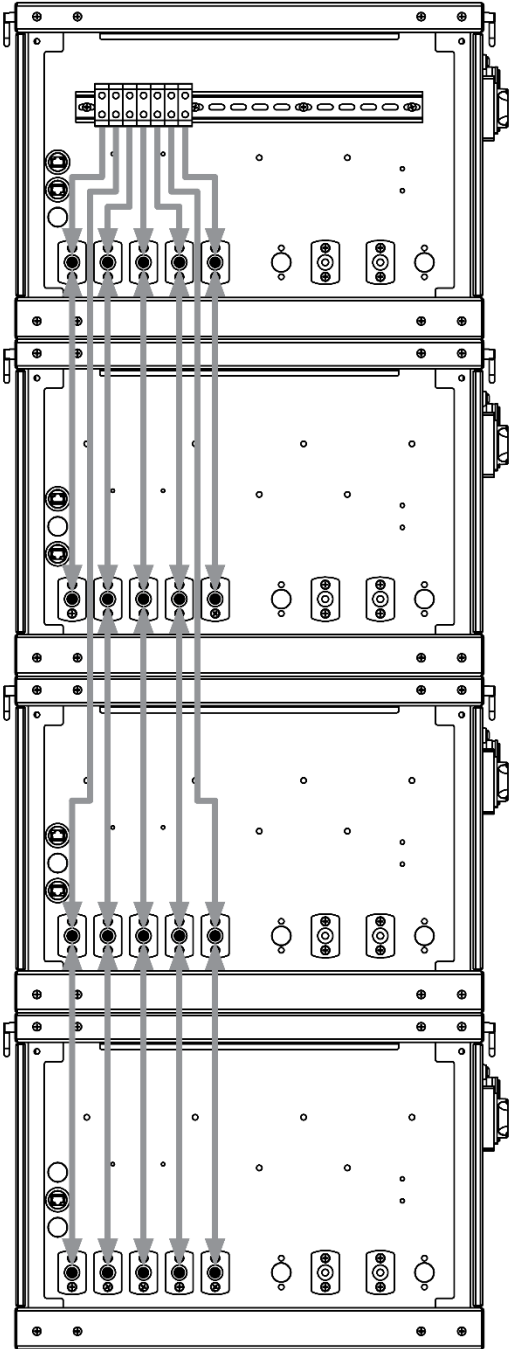

D) AC Wiring Diagram for "P60" Models:

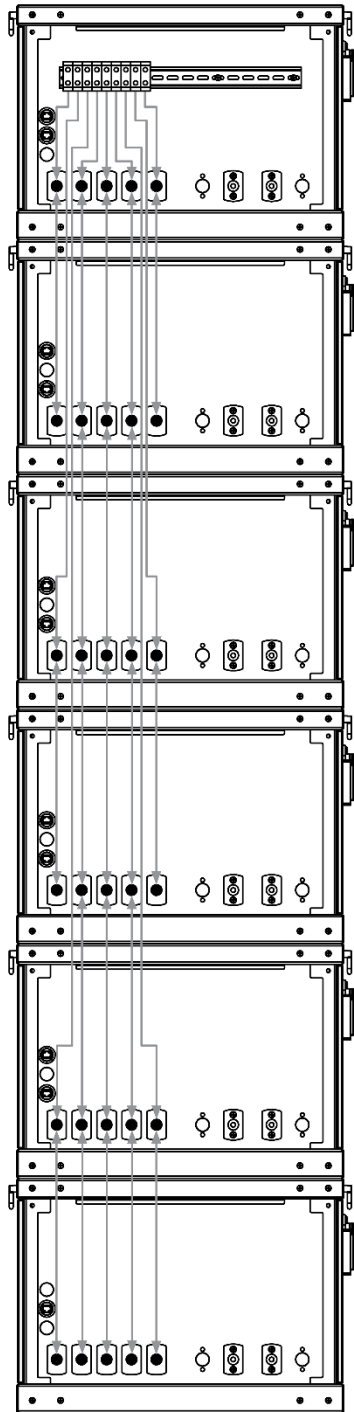

The **AC Input and Output Power Connections** are now complete, and you are ready to move along to the **DC Power Connections** procedure to properly energize the system.

4) DC Power Connections:

Depending on your model number, please follow the appropriate sequence to power the system's batteries, if necessary:

A) Lead-Acid Battery System, Models with "XXLA48"

Battery boxes will arrive pre-wired internally. Connect the included external cables to the Power studs on the back of each stainless steel Battery Box. Connect the other end of the cables to the Red and Black terminals on the side of each Inverter Box to complete the DC power connection.

B) Lithium-Ion Battery System, Models with "XXLI48"

The power connections for lithium Battery systems will vary from model to model. Depending on the model number, the system will have a pre-determined amount of power cables that connect to the inverters, and jumper cables that connect from one battery to the next. Please see labels on longer length DC power cables to connect to the proper lithium-ion battery DC ports.

5) Additional Connections Required:

All Inverters require communication with each other to properly function. This is done through RJ45 cables, which will connect from one Inverter Box to the adjacent Inverter Boxes. See labels on RJ45 ports on interior panel behind Front Cover to install Communication Cables.

Additionally, the lithium-ion batteries require communication between all batteries and inverters, via RJ45 cable. To communicate with the Inverters, the "Master" battery (First battery in sequence) will connect to the RJ45 "INV.COM" port. This cable will come with a pre-programmed Communication Switch Box that allows the batteries to properly communicate with the inverters.

Each battery will also require a communication cable that will connect from one battery to the next. To do so, connect the included Communication Jumper Cables from the first battery's RJ45 "Link.OUT" port to the RJ45 "Link.IN" port of the next battery in the sequence.

Each lithium-ion battery will also need to be grounded, via the grounding stud found on each battery. The grounding cables can be daisy-chained from one battery to the next. The bottom lithium-ion battery in the first stack (if more than one stack) will then need to be properly grounded.

Please refer to the example diagram below to ensure all communication and grounding cables are connected properly:

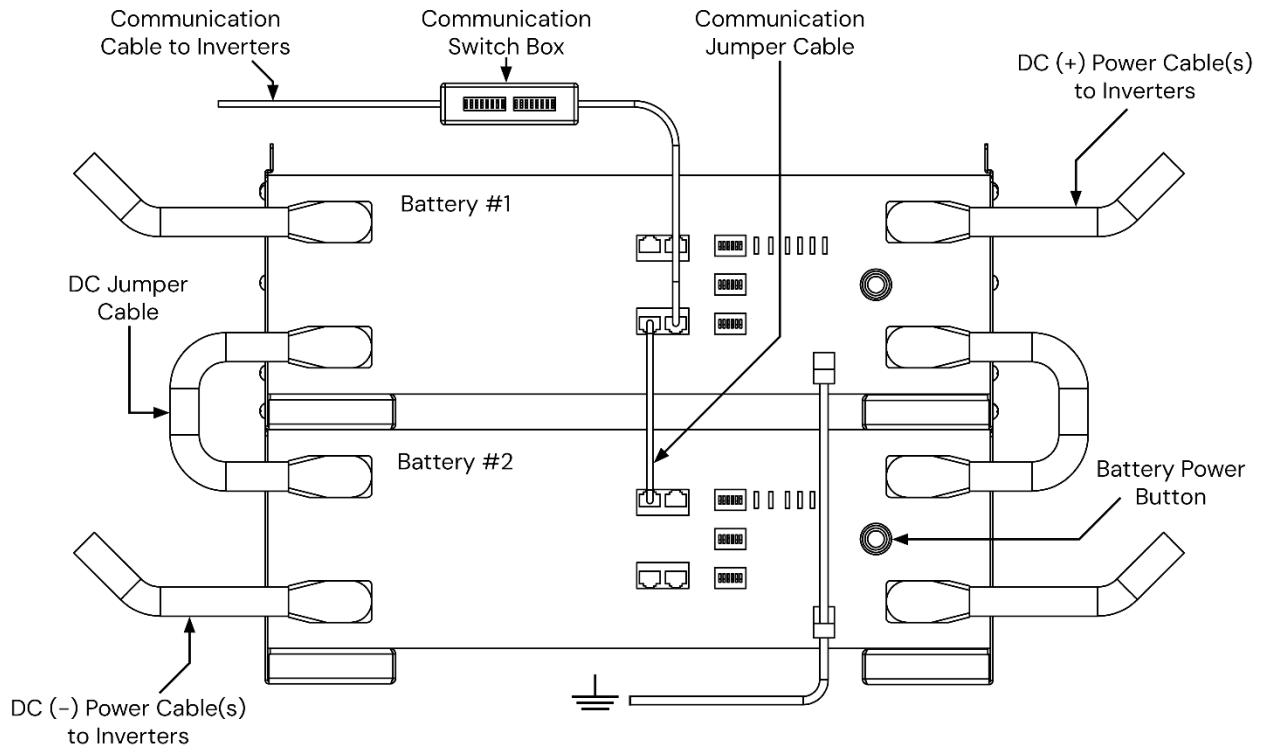

Figure 6

All wiring (AC, DC, and additional cabling) is now complete, and you are ready to move along to the **Unit Startup Procedure** to properly energize the system.

Unit Startup Procedure

Upon completing each step of the Installation process, follow these steps to start using your system. If at any point a step is unsuccessful, or you have any questions, please call our Technical Support line for assistance, at 800-765-3237.

Before you begin, ensure that the system is unpowered by the main supply, the red disconnect switch is set to the "OFF" position, and the Control Panel's toggle switch on the front is set to the "OFF" position. Depending on your system's model number, please follow the appropriate sequence to power on the system's batteries, if necessary:

1) Lead-Acid Battery System, Models with "XXLA48":

Batteries require no "power on" sequence, system is ready to energize.

2) Lithium-Ion Battery System, Models with "XXLI48":

Each lithium-ion battery will need to be turned on individually. Locate the round silver Power button on the front face of the battery. Each battery will need to be powered on in the same sequence as how they were assembled, refer back to Figure 2 for this. When powered on, the battery "ALM" light will illuminate, this is typical. Once all batteries have been powered on, please allow ~2-5 minutes for the "ALM" lights to clear. The batteries are now properly powered on, and the system is ready to energize.

Once the batteries have been turned on, and all "ALM" lights have been cleared, you can install the front cover on each battery. Each battery has its own front cover, that will screw into the hex head screws on the side of the battery. Do so by using the included screws to secure each front cover.

You may now begin the **Unit Startup Procedure**:

- 1) To begin, turn the red switch on the side of each Inverter Box to the "ON" position. This connects the battery bank to the inverters inside.

- 2) Next, turn the toggle switch on the Control Panel on the front cover to the right, to the "Auto On" position. The "Inverter On" light should illuminate, and the system is now drawing energy from the battery bank to power the load.

- 3) Connect an appliance to the unit's output and ensure that your appliance will run on battery power.

Note: If you are powering a refrigerator or freezer, make sure you test it long enough to see that the appliance's compressor turns on. You can speed this process up by opening the door of the appliance.

- 4) Once the output has been verified, apply main power to the system. Do this by switching on the circuit breaker that feeds the unit's input power. After waiting a few seconds, the "Utility On" light should now illuminate, as well as one of the three charging indicator lights (Bulk, Absorption, or Float) below, and the previously illuminated lights will disappear. The system will now pass-through power to the load, and charge the batteries as well.

- 5) Again, verify that the appliance is still receiving power.

- 6) The system is now operational and has been verified to work solely on battery power, as well as the main power supply from the facility.

Operation

During normal operation, when the system is plugged in and main power supply is available, the “Mains On” indicator will be illuminated. The system will also automatically charge the batteries, so one of the three charging light indicators will be illuminated as well. The toggle switch should always be in the “On” position, unless the system is being serviced, or batteries are being changed. This will ensure the system is ready to continue powering the appliance when main power supply is lost. The LCD screen should always show “AC 1”, this setting locks out the knob from changing settings. If the LCD displays anything different, please contact our technical support team. This image below shows an example of what the screen should look like, keep in mind the actual charging LED may differ, depending on state of charge:

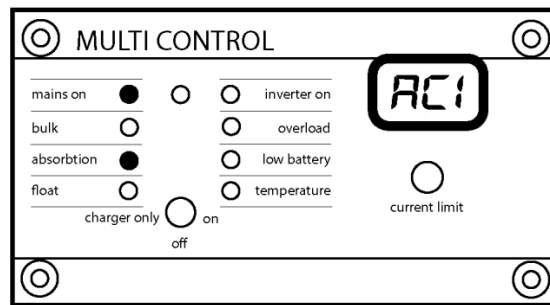

Output Indicators

Inverting: This indicates there is no input power present, and the inverter is drawing from its batteries:

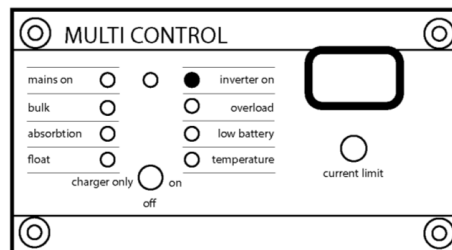

Batteries are low: This indicates that the system batteries are low. If the unit is supporting a load, it will not be long before the batteries go dead:

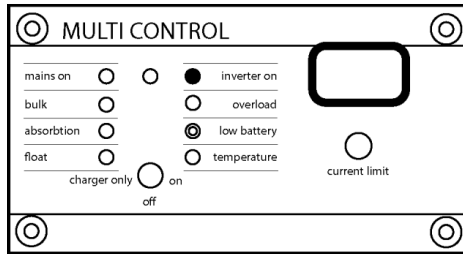

Batteries are dead: This indicates that the battery voltage has gone too low, and the inverter has switched off:

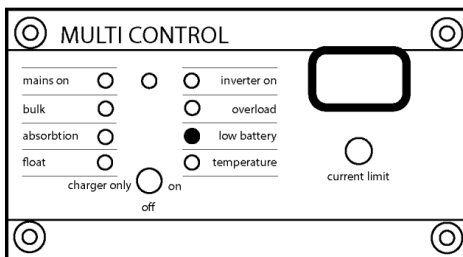

Temperature warning: The unit's internal temperature is reaching a critical level:

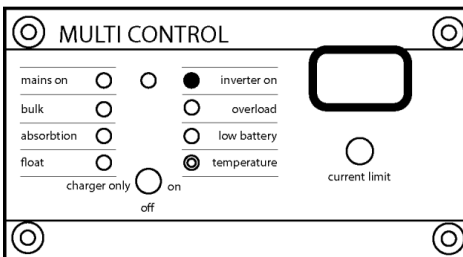

Excess Overload: The equipment load is exceeding the unit's regular output, reduce the equipment load:

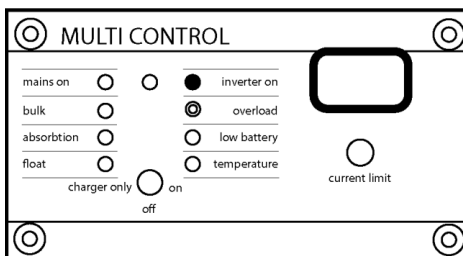

Overload: This indicates that the unit is overloaded due to either a short circuit on the output or the equipment load is too large for the system to support:

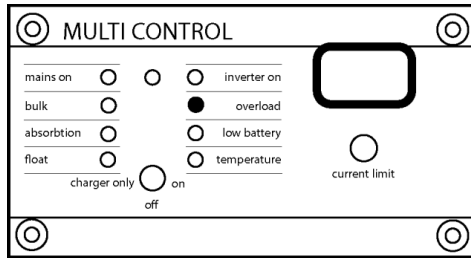

Temperature overload: The unit has reached an internal temperature level that is too high, and the unit shut off:

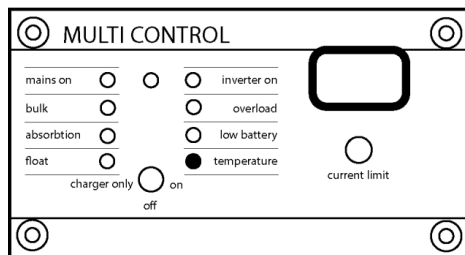

Battery voltage too high: The unit's battery voltage is too high; be sure the correct batteries are being used and they are installed correctly:

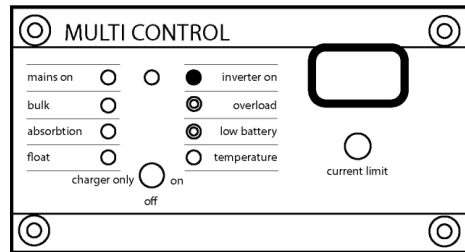

Erratic battery voltage: The unit shut down due to excess ripple voltages out of the battery:

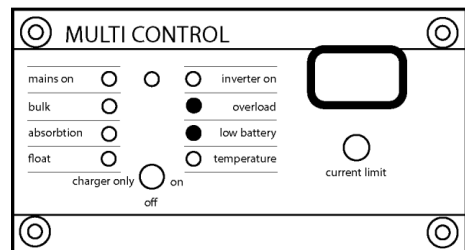

Charging Indicators

Bulk Charge: The unit has AC input voltage and is bulk charging the battery bank while passing the power through to the equipment load:

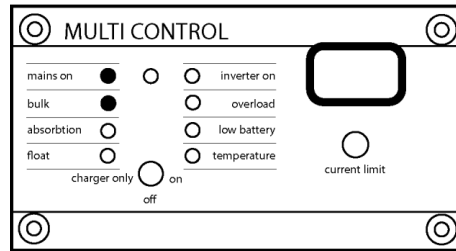

Bulk/Absorption Charge: The unit has AC input voltage and is bulk charging but not yet reached absorption voltage yet:

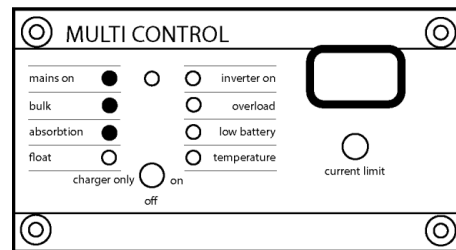

Absorption Charge: The unit has AC input voltage and is absorb charging the battery bank while passing the power through to the equipment load:

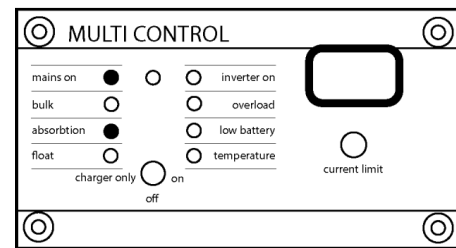

Float Charge: The unit has AC input voltage and is float charging the battery bank while passing the power through to the equipment load:

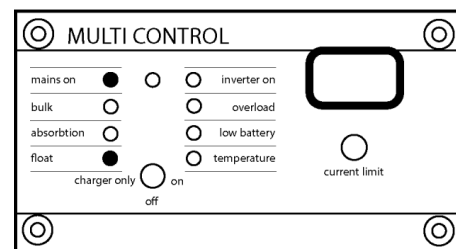

Equalize Mode: The unit has AC input voltage and is equalizing battery bank while passing the power through to the equipment load:

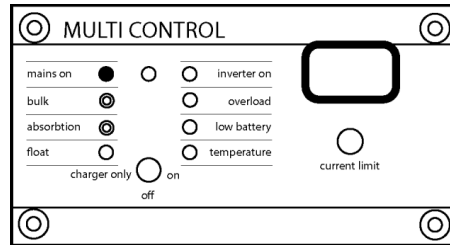

Special Indicators

Power Assist: The unit is supplied with input power, but the output has exceeded the max input setting causing the inverter to assist the support of the load from the batteries:

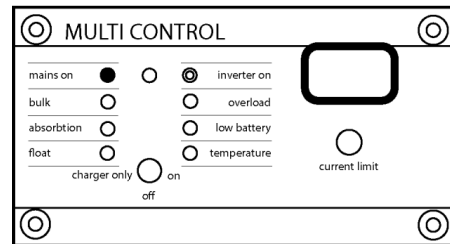

AC Input Max: The unit is supplied with input power, but the output has reached max input setting:

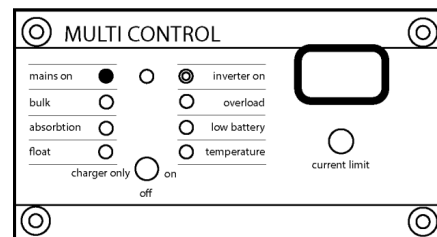

Troubleshooting

| Problem | Cause | Solution |
|--|---|--|
| Inverter will not turn on. | The battery voltage is too high or too low for the inverter to start or it is not connected. If your unit has a DC switch be sure it is switched to on. | Check the battery voltage is in the correct range. If the DC voltage is good, check the internal ANL fuse. |
| Low Battery LED is flashing. | The battery voltage is low | Charge the battery by connecting the input power. |
| Low Battery LED is illuminated. | The unit has switched off because the battery voltage is too low. | Charge the battery by connecting the input power. |
| Overload LED is flashing. | The unit's load is higher than its nominal output load size. | Reduce the amount of equipment that the power system is supporting. |
| Overload LED is illuminated. | The unit switched off because the supported load is too high. | Reduce the amount of equipment that the power system is supporting. |
| Low battery and overload LED lights are flashing intermittently | Battery voltage is low due to a high load | Reduce the load and recharge the batteries. |
| Low battery and overload LED lights are flashing simultaneously. | Ripple voltage from the batteries exceeds 1,5Vrms | Check the battery cables and connections ensure that all connections are tight. |
| The low battery and overload LED lights are lit up | The unit switched off due to a high battery ripple voltage | Check the battery cables and connections ensure that all connections are tight. |

| | | |
|--|--|--|
| The Charger will not operate but the mains LED and the Bulk LED are lit. | The unit has been in bulk charge too long (over 10 hours) | Check the batteries and all the battery connections. Replace the batteries if they will not charge or will not hold a charge. |
| Battery Charger will not operate | AC input voltage is not present. | Check to be sure that the unit is plugged in, or the input circuit is not tripped. Restore input power to the unit if input power has been lost. |
| | The internal battery fuse is blown | Check the Internal ANL Battery fuse replace it if necessary. |
| | Battery voltage is too low for the inverter to recognize it. | Recharge the batteries with an external charger. |

Common problems encountered when installing system

Phase mismatch (“Split” / Three Phase) – use rotation meter and swap phases to rectify, needs to be Clockwise rotation.

Correct rotation (“Split” / Three Phase), system still not charging – Check neutral connection. System requires a neutral connection to function properly. If necessary, trace neutral in building to identify if there is a problem there. If no Neutral line is available, an isolation transformer may be necessary to create this connection.

Qualified Technical Support

Adjustments can be made to the inverter module, if necessary. Please consult with technical service prior to making any adjustments, as unit should arrive with adjustments preset.

A large amount of energy is stored in the batteries which can cause injury to unqualified persons attempting to effect repairs. Also, no one untrained regarding electrical energy should attempt any service task or remove any of the front covers as live circuits will be exposed in all cases.

Eye protection should be worn by any person connecting or disconnecting batteries and battery cables. Hand & Eye Protection is recommended for any person handling batteries.

Testing Procedure

Standards of testing the power system must be implemented and carried out along with your regular testing policies.

Medi-Products sets out the following guidelines and instructions that must be understood and implemented for the use and dependence on our battery backup generators.

Weekly, and Monthly load tests must be performed, recorded and documented. The following criteria must be followed to complete each test:

Weekly Testing:

The recommended weekly test is a quick and simple test which assures the functionality of the transfer switch, auto-invert and charge modes.

This test is performed by disconnecting the power that feeds the battery backup unit or if your system is a plug and play standalone system, unplug its power cord. Upon disconnecting the feed power, your system should switch over to invert mode and draw its power from the batteries. At this point, you should be sure your equipment is still on and running.

Note: If you need to find out your “runtime” contact technical support with your power system’s model and serial number and the make and model of the refrigerator or freezer you are supporting. If you are supporting operating room equipment the standard runtime is 2 hours.

After you have ensured that your system has switched over and is inverting, you will need to restore the feed power (or plug the system back in). This test should not last more than 2 to 3 minutes.

Monthly Testing:

The monthly test is a load test that needs to be conducted no sooner than 20 days and no longer than 40 days from the prior (monthly) load test. This test is to ensure the generator can last 25% of its intended runtime. Your runtime is a predetermined amount of time that your refrigerator will run on the battery backup. This would have been calculated at the time you purchased the unit.

Example: 12 hour run time = Monthly test 3 hours

For the week you are performing the monthly test, it is not necessary to also perform the weekly test.

Another important issue to take note of is that it is possible to over test your power system. Medi-Products battery backup system's use AGM or Lithium-ion batteries, which if discharged too frequently or discharged too deeply, can cause damage to the batteries, shortening their life expectancy and weakening the health of the battery.

You may want to set a timer to remind you to restore the input power to the system and not over discharge the batteries. Reconnect the input power and recharge the battery bank. This may take several hours.

Record Keeping:

Recording these tests is important for the protection of your vaccines and costly inventory. You can use our example test logs on the following page, and can download more from our website if needed.

Maintenance Procedure

The Medi-Products system contains virtually no moving or lubricated components and therefore requires almost no user maintenance aside from testing, recordkeeping and periodically replacing the batteries. If the system has Lead-acid batteries (“XXLA48”, or “XXLA480”) we suggest replacing the batteries every 4 years. If the system has Lithium-ion batteries (“XXLI48”) we suggest replacing the batteries every 10 years.

The user should be aware that by their nature, battery life is negatively affected by some usage patterns. Of course, batteries are intended to be used, but minimizing deep discharges, and frequent charge / discharge cycles will extend overall life.

The system has a battery voltage alarm which will sound when the battery voltage drops below a set value. Battery voltage indicators should be checked if the alarm sounds. Often a low battery alarm will result from a tripped input supply breaker in the main building electric panel. If this is not the cause, please contact Medi-Products promptly.

Unit Shut Down and Battery Replacement Procedure

If the system needs to be turned off, to move the system, or replace the battery modules, please follow these steps:

- 1) Begin by ensuring all appliances are powered via different means while the system is being disconnected, to avoid any damage or loss of power.
- 2) Next, turn the toggle switch on the Control Panel on the front cover to the "OFF" position. All lights on the Control Panel will turn off, and all output power will be lost.
- 3) Now, turn each red battery disconnect switch to the "OFF" position, and remove the main power supply by flipping the main breaker that feeds the system. This disconnects all power to the inverters inside the UPS system.
- 4) Refer to the following to replace the batteries in your system, based on the type of battery included:

A) If your system utilizes Lead-acid batteries ("XXLA48", or "XXLA480", in model number) follow the instructions below:

- 1) Begin by removing all battery cover panels on the stainless steel carts, by unscrewing the two screws holding them in place.
- 2) Remove all battery cables that connect each battery, as well as the bracket that holds the batteries in place. It may help to take a picture or note the configuration of the battery cables before removing, to help when reinstalling.
- 3) Remove each of the old batteries, replace them with the new batteries, and reinstall battery cables and hold down bracket in same configuration as the original.
- 4) Place battery covers back, and secure with the two original screws.

B) If your system utilizes our low voltage lithium-ion batteries (“XXLI48” in model number) follow the instructions below:

1) Begin by turning each battery off by pressing the silver Power Button found on the front face of the each battery.

2) Once the system is completely powered off, remove any necessary DC Power cables, Communication cables, and grounding cables. This is to physically allow the battery to be removed.

3) Once the cables have been disconnected, dismount each battery, and set aside.

4) Replace each old battery with a new battery, and follow the proper installation procedure to ensure the system will operate as intended.

5) Refer back to the **Installation** section of this manual to re-install the system, now using the new battery modules, if they are being replaced.

6) Now that the battery modules have been replaced and the system has been re-installed, please refer to the **Unit Startup Procedure** section to verify that the system is operational again.

Warranty Activation Form

Medi-Products warrants that your Emergency Power System is assembled using high quality components and workmanship and is free of defects in material and workmanship. This warranty shall remain in effect for two (2) years from the date of the original consumer purchase of the inverter. Warranty on the batteries is pro-rated over 48 months.

THIS WARRANTY DOES NOT COVER:

- 1) Replacement parts or labor furnished by anyone other than Medi-Products approved service agent. (All approved agents should be licensed electricians or bio-medical technicians or as specifically approved).
- 2) Defects or damage caused by labor furnished by someone other than Medi-Products or an approved service agent.
- 3) Any malfunction or failure of this product while it is in the possession of the owner during the warranty period, if the malfunction or failure is not caused by a defect in material and workmanship of Medi-Products, or if the malfunction or failure is caused by unreasonable use, including the failure to verify the equipment's utility and usefulness prior to emergency conditions.
- 4) Normal battery depletion.

ALSO:

- 1) This warranty is non-transferable to other owners of the product during the warranty period without the express written consent of Medi-Products.
- 2) Medi-Products reserves the right to repair, replace, or allow credit for any material returned under this warranty. Any damage caused by the customer will be charged or deducted from this allowance.
- 3) All warranty work will be performed at Medi-Products factory or using a valid Warranty Authorization Number (WAN) prior to repair. Products shall be delivered to Medi-Products factory freight prepaid and fully insured.

The inverter manufacturer's owner's manual is provided. The owner should become conversant with it and with this owner's manual. Before operating your system be sure to read these safety instructions.

TO INITIATE YOUR WARRANTY PLEASE COMPLETE THIS FORM AND RETURN WITHIN 30 DAYS

It is recommended that you keep a copy of this activation form for your own records.

Model Number: _____

Serial Number: _____

Date of installation: _____

Facility Name: _____

Contact Name: _____

Phone Number: _____

Fax Number: _____

Email Address: _____

Address where System is installed:

Scan and email this form to sales@mediproducts.com, or you can mail it to
Medicanix Inc. 281 Fields Lane, Suite 2B, Brewster, NY 10509.



Medicanix, Inc. dba Medi-Products

281 Fields Lane, Suite 2B, Brewster, NY 10509

1.800.765.3237 | www.mediproducts.net