

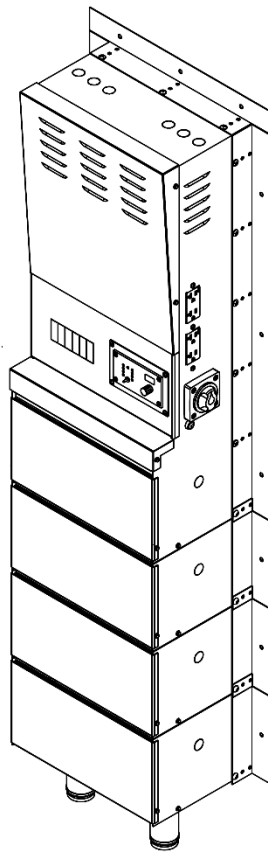

Standalone System User Manual



Model pictured here: SSA2040V

Medicanix, Inc. dba Medi-Products

281 Fields Lane, Suite 2B, Brewster, NY 10509

1.800.765.3237 | www.mediproducts.net

Contents

Contents	1
Safety and Disclaimer	2
Intended Use and Equipment & Wiring Connections	2
Statement of Liability for Medical Environments	2
Installation	3
Pre-installation Steps:	3
Installation Steps:	4
Unit Startup Procedure.....	11
Operation	13
Output Indicators	13
Charging Indicators	16
Special Indicators.....	17
Troubleshooting.....	18
Qualified Technical Support	19
Testing Procedure	20
Weekly Testing:	20
Monthly Testing:	21
Maintenance Procedure	23
Unit Shut Down and Battery Replacement Procedure	24
Warranty Activation Form	25

Safety and Disclaimer

Intended Use and Equipment & Wiring Connections

- This UPS system stores energy. Output battery terminals and possibly output breakers or outlets may be live when the system is turned off or after the input power has been disconnected.
- Please be sure to turn off the electricity in the location where the UPS will be installed prior to working on the unit.
- Please be sure that the power supplied to this unit is the proper phase, voltage and amperage specified.
- The UPS system is required to be powered on a dedicated circuit.
- All hardwired units should be installed by licensed, professional personnel in accordance with local and national codes.
- Although the system is supplied with sealed VRLA batteries they are not leakproof. We recommend that the unit should not be located near explosive medical gas storage, open flame heaters, or electric spark-inducing equipment.

Statement of Liability for Medical Environments

- When used within a surgical environment, do not use in the presence of flammable anesthetic mixtures with air, oxygen, or nitrous oxide.
- This battery backup power system is not intended to support life or run life-supporting equipment but rather to power surgical appliances needed in superficial surgical procedures or medical cold storage appliances. Its use is intended for the supply of emergency power to appliances which may be employed in non-life-threatening medical procedures. It is imperative to understand that at no time should a patient remain unattended. At the time of this manual's writing, the FDA has no classification for a general-purpose medical emergency power supply. This system is not a medical device.
- All life-support type equipment, life-signs monitors, gas monitors etc. are expected to have their own built-in FDA approved appliance-specific energy sources and be maintained correctly. General room lighting and exit signs are also expected to have multiple independent energy sources.
- If life-supporting equipment is to be powered by any sort of electrical source or device, it is Medi-Products' expectation that several alternative independent power supply sources and devices be available.
- Appliances such as refrigerators and freezers, and the contents being stored within them, are the responsibility of the owner/operator to see that they are monitored, maintained and tested. Consequential damages and loss of perishable merchandise are not the liability of Medi-Products/Medicanix.
- It is the sole responsibility of the end user or equipment owner to ensure that the battery backup power system has been tested, maintained, and testing records have been kept and filed.

Installation

Pre-installation Steps:

1) Safety Considerations:

- Read these instructions carefully before attempting to install this product.
- Be sure to leave this manual for end user and save for local inspectors use.
- Observe all governing codes and ordinances.
- Proper installation is the responsibility of the installer.
- Product failure due to improper installation is not covered under the warranty.
- This product should not be altered in any way without manufacturer's consent.
- Be sure all hardwire electrical connections are done by a certified electrical contractor.
- Take special care when working with battery cables, connectors & terminals to make sure they are never short circuited.
- Always wear protective eye, hand and footwear while assembling this system and installing its batteries.

2) Prepare and Check Installation Site:

First, Identify the area on site where you will be installing the system.

Check all measurements to ensure there will be no obstructions. The necessary height and width requirements will vary with each model, please check your specific unit's spec sheet for this information. Please also allow for ~10" of depth that the system will need to occupy.

The space directly in front and on either side of the unit will need to be accessible, to remove the unit's access panels for future servicing, or additional connections. For the front of the system, and the front interface of the batteries, please allow up to 3' of open space if possible. You will also need at least 3" clearance on either side of the system for mounting purposes.

Installation Steps:

Before installing the system, ensure the main utility power is not energized throughout the entire installation process. Please wait until system is fully installed before applying the main utility power to the system. To begin installation, follow the procedure below:

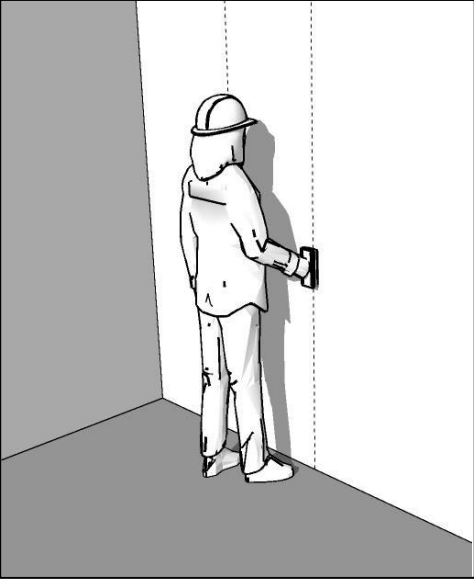
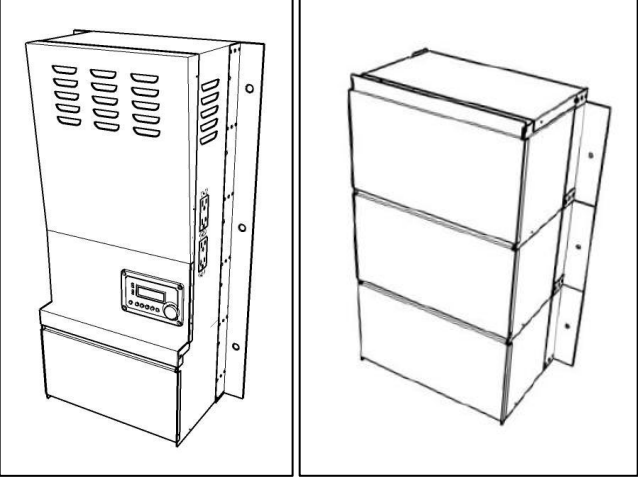
1) Prepare your Wall:	2) Unwrap Unit and Prepare for Mounting:
<p>Locate and mark the wall studs directly behind the intended location where the unit will be mounted using a stud finder. It's important that your unit is fastened to at least 1 sturdy wall stud, preferably 2 if possible.</p>  <p>The illustration shows a person wearing a hard hat and work clothes, standing in a room and using a stud finder on a wall. Two vertical dashed lines are drawn on the wall to indicate the location of wall studs.</p>	<p>Unwrap the Battery Box & Upper Cabinet</p>  <p>The illustrations show two views of the equipment. On the left is a tall, narrow cabinet with a control panel near the bottom. On the right is a stack of three battery boxes, each with a handle on the side.</p> <p>Remove the Battery Box Covers using the ¼" hex driver. Each cover has 2 screws, one on each side. In the top upper battery compartment you will find this User Manual, and the necessary installation hardware. Because the covers overlap you will need to remove the top one first.</p>

3) Mounting and Securing the Unit:

Hold the battery box up to the wall and mark each mounting hole. If possible, be sure that at least one of the side rails is lined up with a wall stud (ideally attach to 2 wall studs whenever possible).

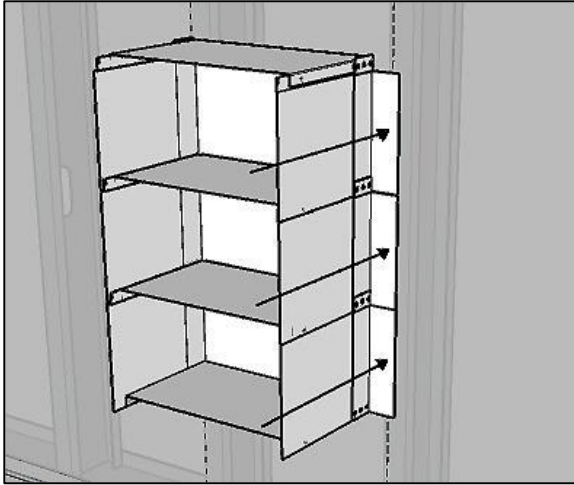

For units with 3 or more batteries, we recommend supporting the unit's weight on the unit's feet on the floor as shown:

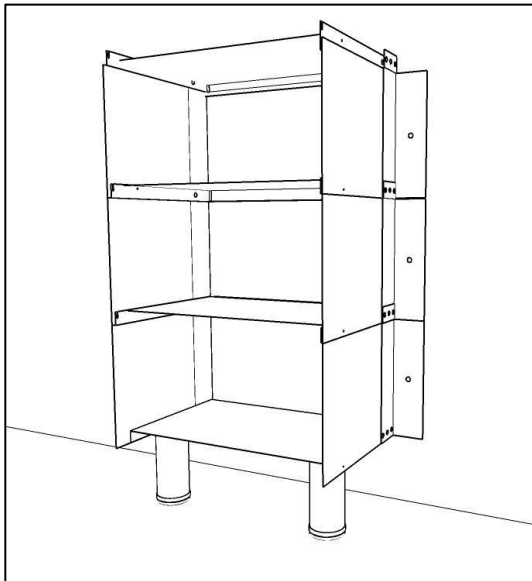

3) Mounting and Securing the Unit (Cont'd):

Note: If the area restricts the possibility of lining up the mounting flanges with the wall studs, remove each battery box cover and drill a 5/16" hole in each compartment thru the rear of the cabinet in a location that lines up with a stud. (in addition to marking each hole on the mounting flanges)

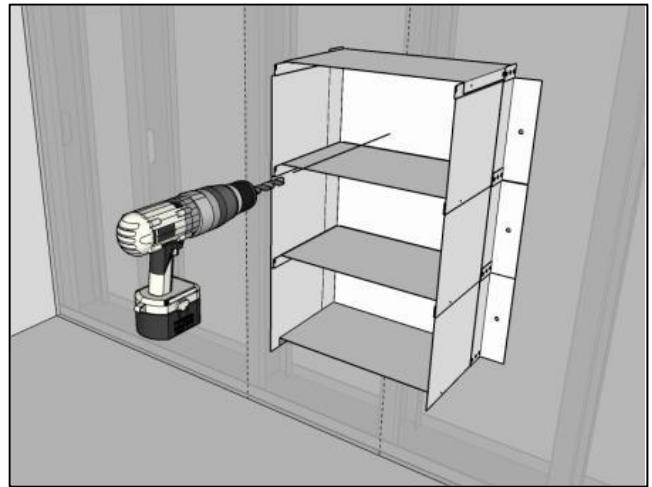

For installations that involve securing to metal studs, drill out the marked-out holes using a 1/2 inch drill bit.

Note: For installations that involve wood studs, predrill the marked holes with the appropriate bit for 3/8" lag bolts.

3) Mounting and Securing the Unit (Cont'd):

Install the provided wall fasteners thru the 1/2" holes securing the toggle nut plate to the metal stud as shown:

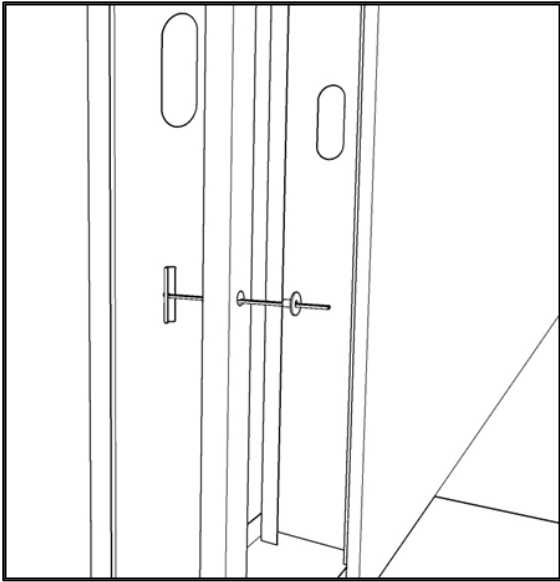

When fastening to the metal stud, it is important that the toggle plate be positioned horizontal and that your hole is positioned in the center of the stud.

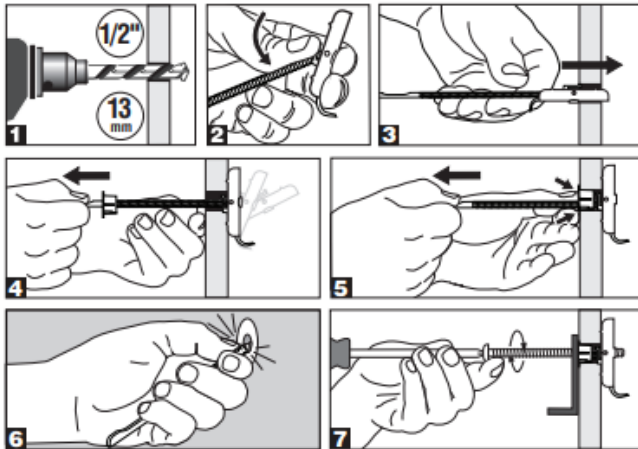

3) Mounting and Securing the Unit (Cont'd):

Once the wall fasteners are all in-place, secure the cabinet to the wall using the 1/4 -20 anchor bolts with the fender washers:

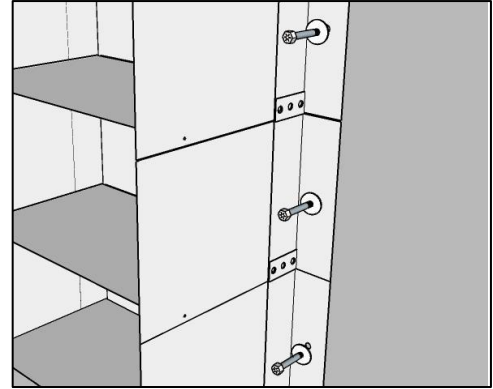

Once the battery cabinet is securely fastened place the upper cabinet onto the lower cabinet. The upper cabinet will be supported with the temporary wooden installation support.

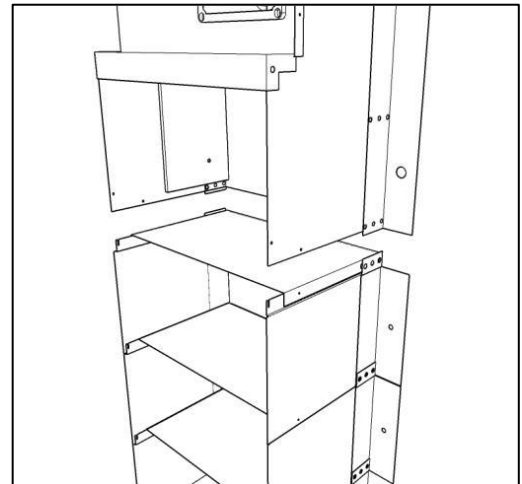

3) Mounting and Securing the Unit (Cont'd):

The upper cabinet shell should surround the outside of the top battery box shelf but be positioned behind the top ear of the side angle bracket as shown:

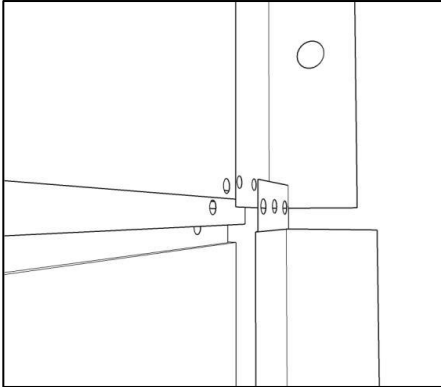

Install the top angle bracket to the upper cabinet:

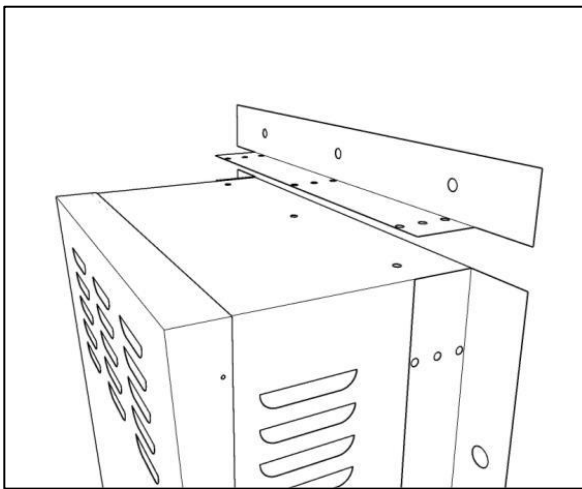

3) Mounting and Securing the Unit (Cont'd):

Mark the wall where the 6 mounting holes are located along each sides of the upper cabinet mounting angles, and the 3 holes along the top mounting angle.

Remove the top cabinet, set it aside while you drill each of the 9 marked holes with a 1/2" drill bits.

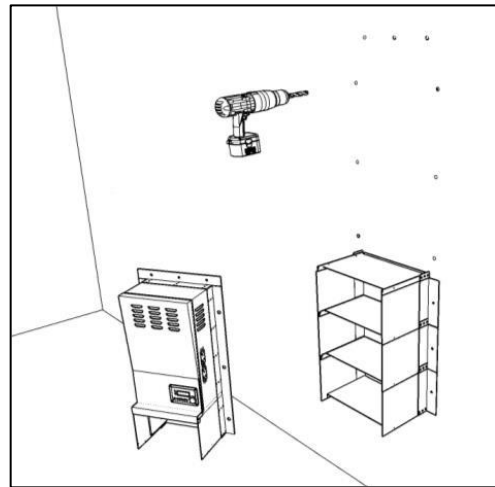

3) Mounting and Securing the Unit (Cont'd):

Install the wall toggle fasteners in each 1/2" hole securing them to the metal studs.

Re-Position the upper cabinet onto the lower cabinet.

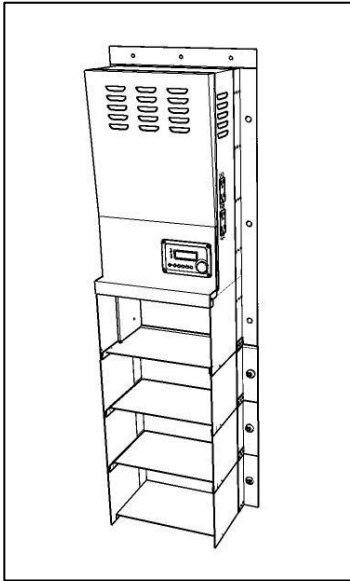

Install the 2x 1/4"-20 Philips pan head bolts and 2x #8 sheet metal screws on each side of the cabinet securing the upper lower cabinet to the lower cabinet.

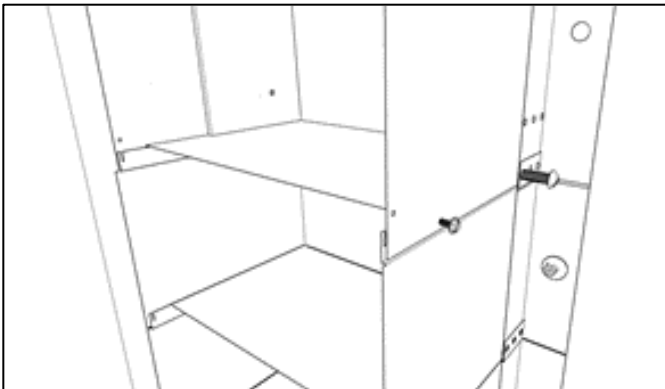

3) Mounting and Securing the Unit (Cont'd):

Finish securing the upper cabinet to the wall using the 9x 3/8" anchor bolts:

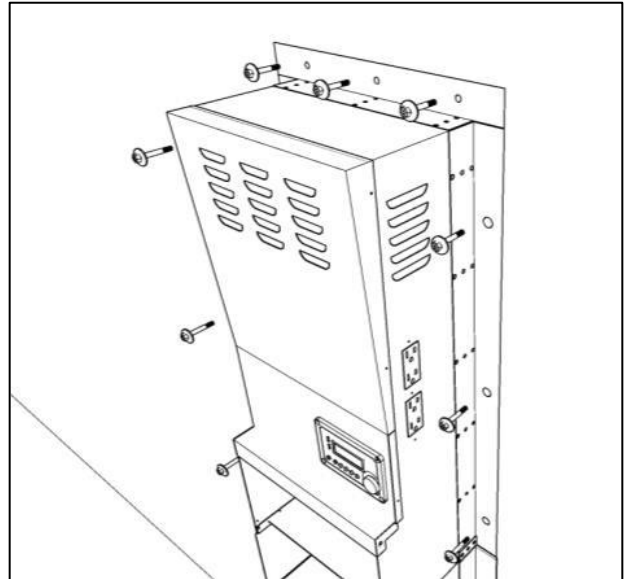

If Necessary: Also mark out the bottom rail. This is only necessary if the unit is mounted high enough that the bottom edge is visible. In order to do so, you will need to drill 1/8" holes and use the sheet metal screws to fasten it to the bottom battery shelf.

4) Installing and Wiring the Batteries:

It is important that you install your battery cables in the correct configuration, depending on the model number of your system. Please see the Table below to identify the correct configuration for your system:

Beginning of Model Number	Wiring Configuration (VDC)
SSA12	12 (if less than 8 batteries), 24 if more
SSA20	24
SSA30	24
SSA50	48

Refer to the following diagram to see detailed explanation of how to wire each configuration:

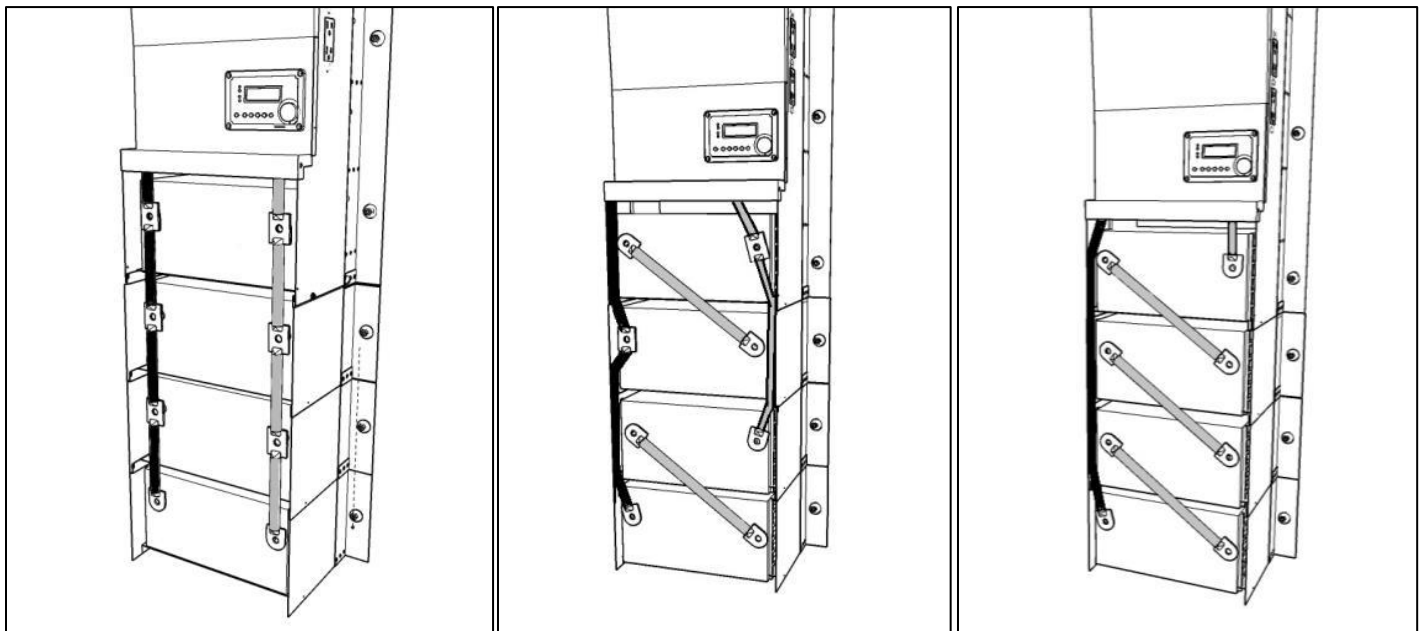

12 Volt

24 Volt

48 Volt

Please note that each battery must be placed in the battery cabinet with the terminals closer to the bottom side, or the supplied battery cables may not reach correctly. Before connecting any battery cables, ensure the red disconnect switch, on the side of the UPS system, is in the "off" position. Connecting batteries with this switch in the "on" position may cause damage to the inverter. If the system does not have a red disconnect switch, connect the positive and negative battery cables coming from the inverter as the last connections. Once batteries are installed and properly wired, reinstall the battery box covers, starting with the bottom cover first, reusing the #8 sheet metal hex nut screws.

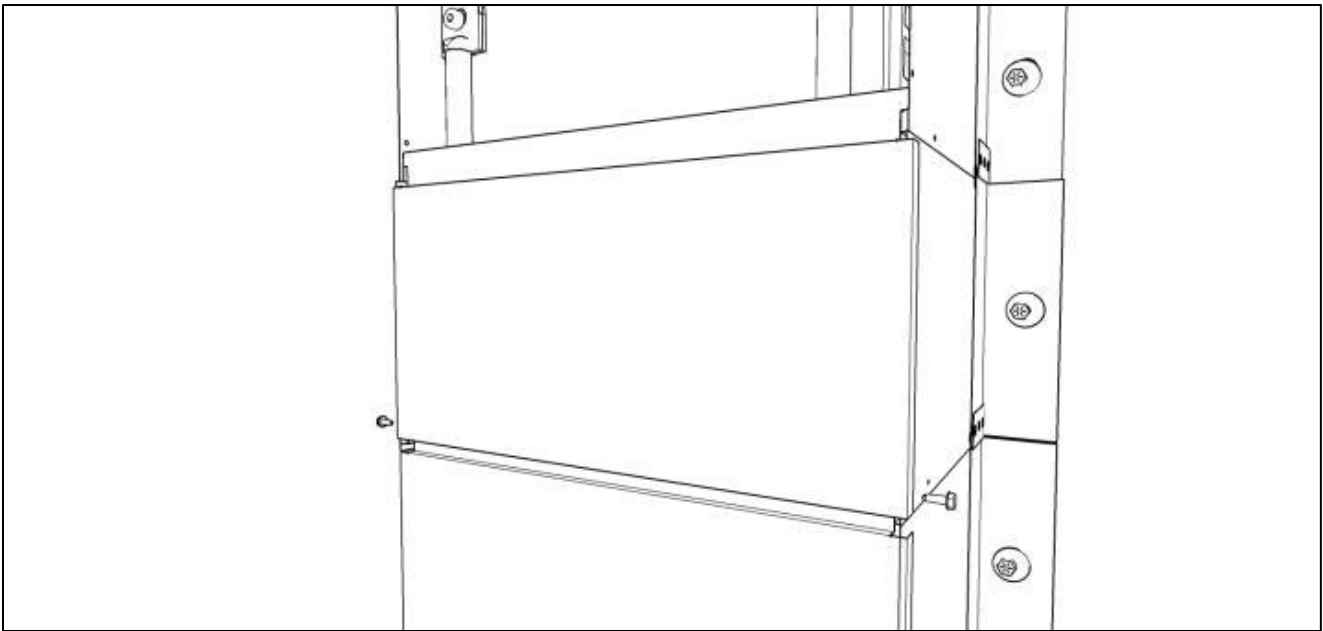

You have now completed mounting the system and wiring the battery bank. Please move to the next section to properly connect the incoming power lines from the main utility supply.

5) AC Input and Output Details:

Once the system and batteries have been installed, the system is ready to be plugged in, and initialized. Before doing so, please see the following table to determine the pertinent electrical information of your system, based on the model number.

Beginning of Model Number	Input / Output Voltage (Volts)	Input Circuit Size (Amps)	UPS Power Cord Plug End Rating	Output Circuit Size (Amps)	Output Outlet Rating
SSA12	120	15	NEMA 5-15P	15	NEMA 5-15R
SSA20	120	20	NEMA 5-20P	20	NEMA 5-20R
SSA30	120	20	NEMA 5-20P	20	NEMA 5-20R
SSA50	120	20	NEMA 5-20P	20	NEMA 5-20R

Unit Startup Procedure

Upon completing each step of the Installation process, follow these steps to start using your system. If at any point a step is unsuccessful, or you have any questions, please call our Technical Support line for assistance, at 800-765-3237.

Before you begin, ensure that the system is unplugged from the wall outlet, the red disconnect switch is set to the "OFF" position, and the Control Panel's toggle switch on the front is set to the "OFF" position.

- 1) To begin, turn the red switch on the side of each Inverter Box to the "ON" position. This connects the battery bank to the inverters inside. If the system does not have a red disconnect switch, disregard this step.
- 2) Next, turn the toggle switch on the Control Panel on the front cover to the right, to the "Auto On" position. The "Inverter On" light should illuminate, and the system is now drawing energy from the battery bank to power the load.

3) Plug in an appliance to one of the unit's outlets and ensure that your appliance will run on battery power.

Note: If you are powering a refrigerator or freezer, make sure you test it long enough to see that the appliance's compressor turns on. You can speed this process up by opening the door of the appliance.

4) Once the output has been verified, apply main power to the system. Do this by plugging in the system's power cord. After waiting a few seconds, the "Utility On" light should now illuminate, as well as one of the three charging indicator lights (Bulk, Absorption, or Float) below, and the previously illuminated lights will disappear. The system will now pass-through power to the load, and charge the batteries as well.

5) Again, verify that the appliance is still receiving power.

6) The system is now operational and has been verified to work solely on battery power, as well as the main power supply from the facility.

Operation

During normal operation, when the system is plugged in and main power supply is available, the “Mains On” indicator will be illuminated. The system will also automatically charge the batteries, so one of the three charging light indicators will be illuminated as well. The toggle switch should always be in the “Auto On” position, unless the system is being serviced, or batteries are being changed. This will ensure the system is ready to continue powering the appliance when main power supply is lost. The LCD screen should always show “AC 1”, this setting locks out the knob from changing settings. If the LCD displays anything different, please contact our technical support team. This image below shows an example of what the screen should look like, keep in mind the actual charging LED may differ, depending on state of charge:

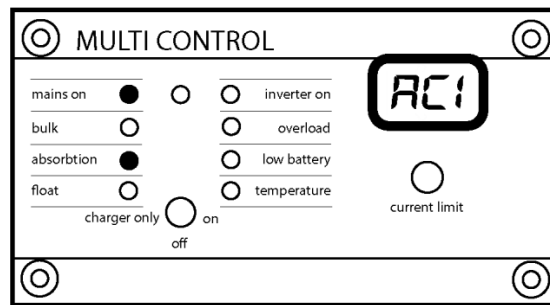

Please see the additional Indicator light configurations on the following pages, to better understand your system’s status at any given time:

Output Indicators

Inverting: This indicates there is no input power present, and the inverter is drawing from its batteries:

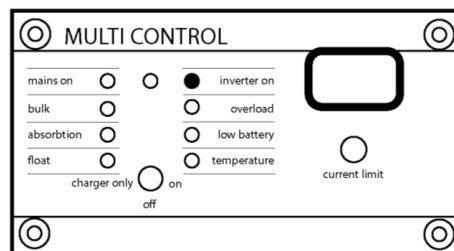

Batteries are low: This indicates that the system batteries are low. If the unit is supporting a load, it will not be long before the batteries go dead:

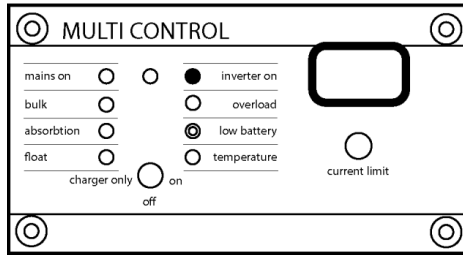

Batteries are dead: This indicates that the battery voltage has gone too low, and the inverter has switched off:

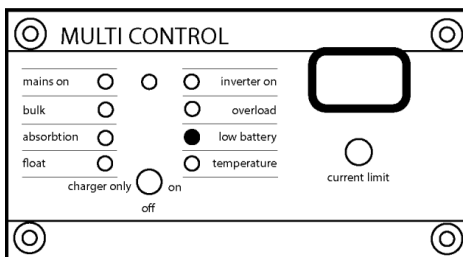

Temperature warning: The unit's internal temperature is reaching a critical level:

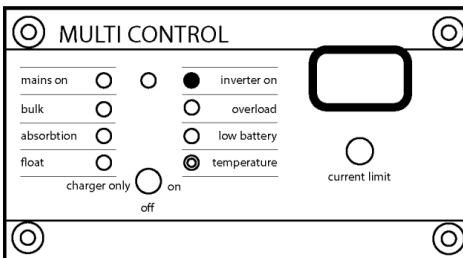

Excess Overload: The equipment load is exceeding the unit's regular output, reduce the equipment load:

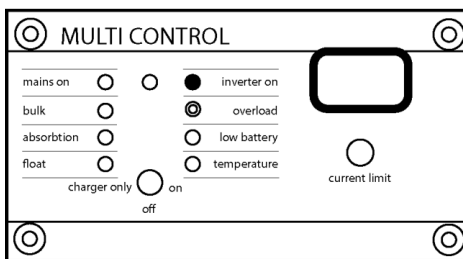

Overload: This indicates that the unit is overloaded due to either a short circuit on the output or the equipment load is too large for the system to support:

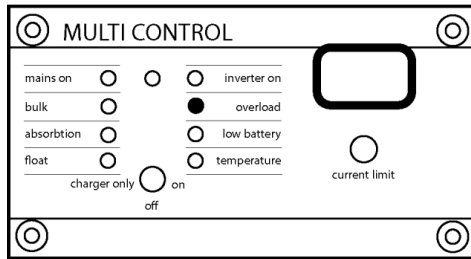

Temperature overload: The unit has reached an internal temperature level that is too high, and the unit shut off:

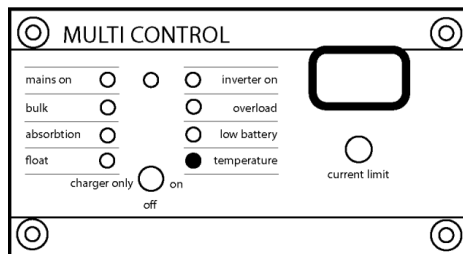

Battery voltage too high: The unit's battery voltage is too high; be sure the correct batteries are being used and they are installed correctly:

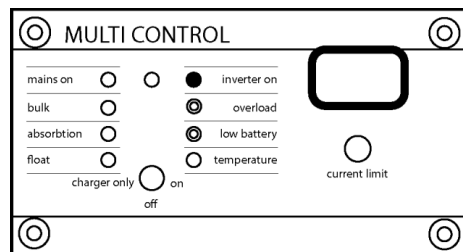

Erratic battery voltage: The unit shut down due to excess ripple voltages out of the battery:

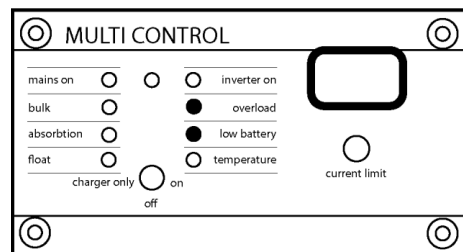

Charging Indicators

Bulk Charge: The unit has AC input voltage and is bulk charging the battery bank while passing the power through to the equipment load:

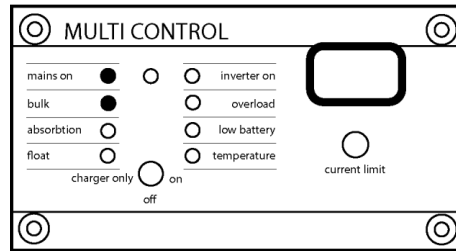

Bulk/Absorption Charge: The unit has AC input voltage and is bulk charging but not yet reached absorption voltage yet:

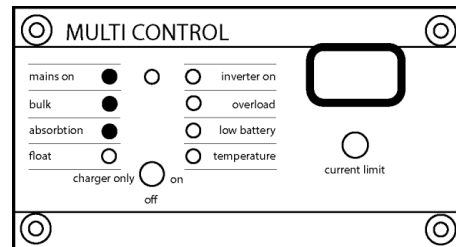

Absorption Charge: The unit has AC input voltage and is absorb charging the battery bank while passing the power through to the equipment load:

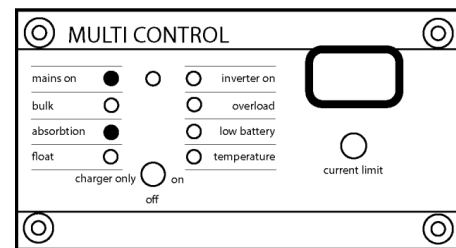

Float Charge: The unit has AC input voltage and is float charging the battery bank while passing the power through to the equipment load:

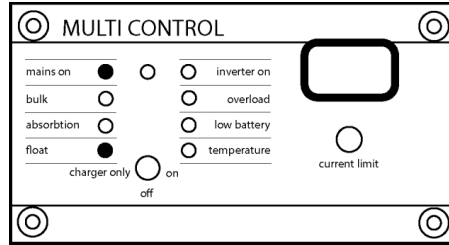

Equalize Mode: The unit has AC input voltage and is equalizing battery bank while passing the power through to the equipment load:

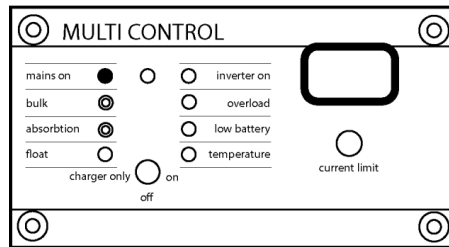

Special Indicators

Power Assist: The unit is supplied with input power, but the output has exceeded the max input setting causing the inverter to assist the support of the load from the batteries:

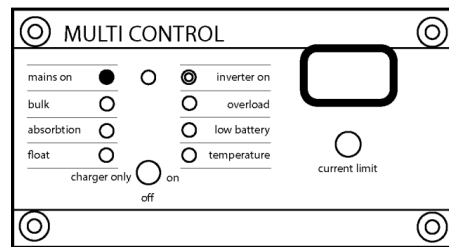

AC Input Max: The unit is supplied with input power, but the output has reached max input setting:

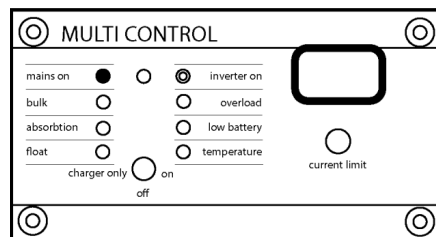

Troubleshooting

Problem	Cause	Solution
Inverter will not turn on.	The battery voltage is too high or too low for the inverter to start or it is not connected. If your unit has a DC switch be sure it is switched to on.	Check the battery voltage is in the correct range. If the DC voltage is good, check the internal ANL fuse.
Low Battery LED is flashing.	The battery voltage is low	Charge the battery by connecting the input power.
Low Battery LED is illuminated.	The unit has switched off because the battery voltage is too low.	Charge the battery by connecting the input power.
Overload LED is flashing.	The unit's load is higher than its nominal output load size.	Reduce the amount of equipment that the power system is supporting.
Overload LED is illuminated.	The unit switched off because the supported load is too high.	Reduce the amount of equipment that the power system is supporting.
Low battery and overload LED lights are flashing intermittently	Battery voltage is low due to a high load	Reduce the load and recharge the batteries.
Low battery and overload LED lights are flashing simultaneously.	Ripple voltage from the batteries exceeds 1,5Vrms	Check the battery cables and connections ensure that all connections are tight.
The low battery and overload LED lights are lit up	The unit switched off due to a high battery ripple voltage	Check the battery cables and connections ensure that all connections are tight.

The Charger will not operate but the mains LED and the Bulk LED are lit.	The unit has been in bulk charge too long (over 10 hours)	Check the batteries and all the battery connections. Replace the batteries if they will not charge or will not hold a charge.
Battery Charger will not operate	AC input voltage is not present.	Check to be sure that the unit is plugged in, or the input circuit is not tripped. Restore input power to the unit if input power has been lost.
	The internal battery fuse is blown	Check the Internal ANL Battery fuse replace it if necessary.
	Battery voltage is too low for the inverter to recognize it.	Recharge the batteries with an external charger.

Qualified Technical Support

Adjustments can be made to the inverter module, if necessary. Please consult with technical service prior to making any adjustments, as unit should arrive with adjustments preset.

A large amount of energy is stored in the batteries which can cause injury to unqualified persons attempting to effect repairs. Also, no one untrained regarding electrical energy should attempt any service task or remove any of the front covers as live circuits will be exposed in all cases.

Eye protection should be worn by any person connecting or disconnecting batteries and battery cables. Hand & Eye Protection is recommended for any person handling batteries.

Testing Procedure

Standards of testing the power system must be implemented and carried out along with your regular testing policies.

Medi-Products sets out the following guidelines and instructions that must be understood and implemented for the use and dependence on our battery backup generators.

Weekly, and Monthly load tests must be performed, recorded and documented. The following criteria must be followed to complete each test:

Weekly Testing:

The recommended weekly test is a quick and simple test which assures the functionality of the transfer switch, auto-invert and charge modes.

This test is performed by disconnecting the power that feeds the battery backup unit or if your system is a plug and play standalone system, unplug its power cord. Upon disconnecting the feed power, your system should switch over to invert mode and draw its power from the batteries. At this point, you should be sure your equipment is still on and running.

Note: If you need to find out your “runtime” contact tech support with your power system’s model and serial number and the make and model of the refrigerator or freezer you are supporting. If you are supporting operating room equipment the standard runtime is 2 hours.

After you have ensured that your system has switched over and is inverting, you will need to restore the feed power (or plug the system back in). This test should not last more than 2 to 3 minutes.

Monthly Testing:

The monthly test is a load test that needs to be conducted no sooner than 20 days and no longer than 40 days from the prior (monthly) load test. This test is to ensure the generator can last 25% of its intended runtime. Your runtime is a predetermined amount of time that your refrigerator will run on the battery backup. This would have been calculated at the time you purchased the unit.

Example: 12 hour run time = Monthly test 3 hours

For the week you are performing the monthly test, it is not necessary to also perform the weekly test.

Another important issue to take note of is that it is possible to over test your power system. Medi-Products battery backup system's use AGM batteries, which if discharged too frequently or discharged too deeply, it can cause damage to the batteries, shortening their life expectancy and weakening the health of the battery.

You may want to set a timer to remind you to restore the input power to the system and not over discharge the batteries. Reconnect the input power and recharge the battery bank. This may take several hours.

Record Keeping:

Recording these tests is important for the protection of your vaccines and costly inventory. You can use our example test logs on the following page, and can download more from our website if needed.

Maintenance Procedure

The Medi-Products system contains virtually no moving or lubricated components and therefore requires almost no user maintenance aside from testing, recordkeeping and periodically replacing the batteries (every 4 years).

The user should be aware that by their nature, battery life is negatively affected by some usage patterns. Of course, batteries are intended to be used, but minimizing deep discharges, and frequent charge / discharge cycles will extend overall life. Their life expectancy will be generally in the range of four to five years. Please refer to the section on Battery Testing for more on this subject.

The system has a battery voltage alarm which will sound when the battery voltage drops below a set value. Battery voltage indicators should be checked if the alarm sounds. Often a low battery alarm will result from a tripped input supply breaker in the main building electric panel. If this is not the cause, please contact Medi-Products promptly.

Unit Shut Down and Battery Replacement Procedure

If the system needs to be turned off, to move the system, or replace the batteries, please follow these steps:

- 1) Begin by ensuring all appliances are powered via different means while the system is being disconnected, to avoid any damage or loss of power. If there is a disconnect switch, move that switch to the "Bypass" mode.
- 2) Next, turn the toggle switch on the Control Panel on the front cover to the "OFF" position. All lights on the Control Panel will turn off, and all output power will be lost.
- 3) Now, turn the red battery disconnect switch to the "OFF" position, and remove the main power supply by flipping the main breaker that feeds the system. This disconnects all power to the inverters inside the UPS system.
- 4) If replacing the batteries, begin by removing the battery box covers, one by one.
- 5) Once removed, the battery cables can be disconnected, and the old batteries can be removed from the battery boxes.

Note: Keep in mind the battery cables will be live when disconnecting and reconnecting, so please take the necessary precautions.

- 6) Place the new batteries in the battery boxes, and reconnect the battery cables again. If needed, refer back to the "Installing and Wiring the Batteries" section earlier to assist. The battery box covers can now be reinstalled once again.
- 7) Now that the batteries have been replaced and the system has been re-installed, please refer to the **Unit Startup Procedure** section to verify that the system is operational again.

Warranty Activation Form

Medi-Products warrants that your Emergency Power System is assembled using high quality components and workmanship and is free of defects in material and workmanship. This warranty shall remain in effect for two (2) years from the date of the original consumer purchase of the inverter. Warranty on the batteries is pro-rated over 48 months.

THIS WARRANTY DOES NOT COVER:

- 1) Replacement parts or labor furnished by anyone other than Medi-Products approved service agent. (All approved agents should be licensed electricians or bio-medical technicians or as specifically approved).
- 2) Defects or damage caused by labor furnished by someone other than Medi-Products or an approved service agent.
- 3) Any malfunction or failure of this product while it is in the possession of the owner during the warranty period, if the malfunction or failure is not caused by a defect in material and workmanship of Medi-Products, or if the malfunction or failure is caused by unreasonable use, including the failure to verify the equipment's utility and usefulness prior to emergency conditions.
- 4) Normal battery depletion.

ALSO:

- 1) This warranty is non-transferable to other owners of the product during the warranty period without the express written consent of Medi-Products.
- 2) Medi-Products reserves the right to repair, replace, or allow credit for any material returned under this warranty. Any damage caused by the customer will be charged or deducted from this allowance.
- 3) All warranty work will be performed at Medi-Products factory or using a valid Warranty Authorization Number (WAN) prior to repair. Products shall be delivered to Medi-Products factory freight prepaid and fully insured.

The inverter manufacturer's owner's manual is provided. The owner should become conversant with it and with this owner's manual. Before operating your system be sure to read these safety instructions.

TO INITIATE YOUR WARRANTY PLEASE COMPLETE THIS FORM AND RETURN WITHIN 30 DAYS

It is recommended that you keep a copy of this activation form for your own records.

Model Number: _____

Serial Number: _____

Date of installation: _____

Facility Name: _____

Contact Name: _____

Phone Number: _____

Fax Number: _____

Email Address: _____

Address where System is installed:

Scan and email this form to sales@mediproducts.com, or you can mail it to
Medicanix Inc. 281 Fields Lane, Suite 2B, Brewster, NY 10509.



Medicanix, Inc. dba Medi-Products

281 Fields Lane, Suite 2B, Brewster, NY 10509

1.800.765.3237 | www.mediproducts.net